



Baghdad University  
Collage of Ibn-Al-Haitham for Pure  
Science  
Department of Computer Science



جامعة بغداد  
كلية التربية للعلوم الصرفة / ابن الهيثم  
قسم علوم الحاسبات

المرحلة الرابعة

صباحي + مسائي

(شبكات واتصالات - محاضرات النظري)

ملزمة رقم 1

# Data communication and Networks

## Chapter 1: Computer Networks Overview

Dr. Mohammed Kamal Nsaif

Dr. Wisal Hashim Abdulsalam



Dr. Mohammed Kamal

Let us start our lectures with the following question:

Why wait a week for that letter from Germany to arrive by regular mail when it could appear almost instantaneously through computer networks?

Data communications and networking are changing the way we do business and the way we live. Businesses today rely on computer networks and internetworks (e.g., Internet).

*Data communications* and *networking* enable to exchange data such as text, audio, and video from all points in the world. We want to access the Internet to download and upload information quickly and accurately and at any time.

## 1.1 Data Communication

When we communicate, we are sharing information. This sharing can be local or remote. Between individuals, local communication usually occurs face to face, while remote communication takes place over distance.

The term *telecommunication*, which includes telephony, telegraphy, and television, means communication at a distance (tele is Greek for "far").

*Data communications* are the exchange of data between two devices via some form of transmission medium such as a wire cable. The communicating devices must be part of a communication system which is made up of a combination of **hardware** (physical equipment) and **software** (programs).

The effectiveness of a data communications system depends on four fundamental characteristics:

1. **Delivery.** The system must deliver data to the correct destination.
2. **Accuracy.** The system must deliver the data accurately, without errors.
3. **Timeliness.** The system must deliver data in a timely manner. Data delivered late are useless. In the case of video and audio, timely delivery means delivering data as they are produced, without significant delay (*real-time transmission*).
4. **Jitter.** Jitter refers to the variation in the packet arrival time. It is the uneven delay in the delivery of audio or video packets.

## 1.2 Components of data communications system

A data communications system has five components (see Figure 1.1).

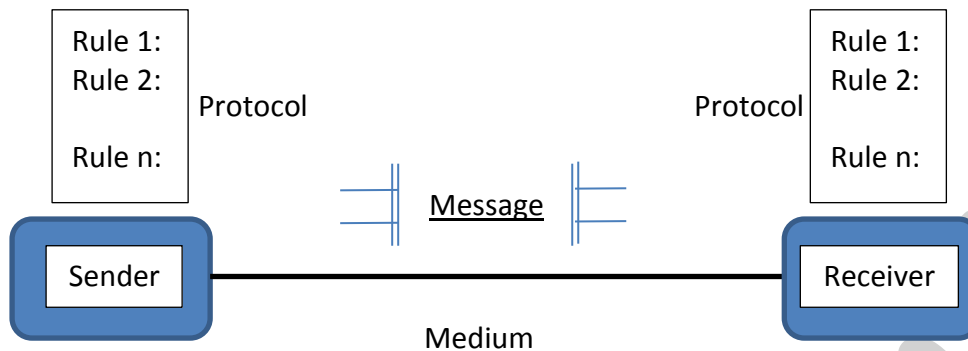

**Figure 1.1** *Five components of data communication system*

1. **Message.** It is the information (data) to be communicated. Popular forms of information include text, numbers, pictures, audio, and video.
2. **Sender.** It is the device that sends the data message. It can be a computer, workstation, telephone handset, video camera, and so on.
3. **Receiver.** It is the device that receives the message. It can be a computer, workstation, telephone handset, television, and so on.
4. **Transmission medium.** It is the physical path by which a message travels from sender to receiver. Some examples of transmission media include twisted-pair wire, coaxial cable, fiber-optic cable, and radio waves.
5. **Protocol.** It is a set of rules that govern data communications. It represents an agreement between the communicating devices. Without a protocol, two devices *may be connected but not communicating*, just as a person speaking French cannot be understood by a person who speaks only Japanese.

## 1.3 Data Representation

Information today comes in different **forms** such as:

***Text, Numbers, Images, Audio, and Video.***

## 1.4 Data Flow

Communication between two devices can be simplex, half-duplex, or full-duplex as shown in Figure 1.2.

**Simplex** In simplex mode, the communication is unidirectional, as on a one-way street. For example, the keyboard can only introduce input; the monitor can only accept output.

**Half-Duplex** In half-duplex mode, each station can both transmit and receive, but not at the same time. When one device is sending, the other can only receive, and vice versa.

**Full-Duplex** In full-duplex mode (also called duplex), both stations can transmit and receive simultaneously, for example, the telephone network.

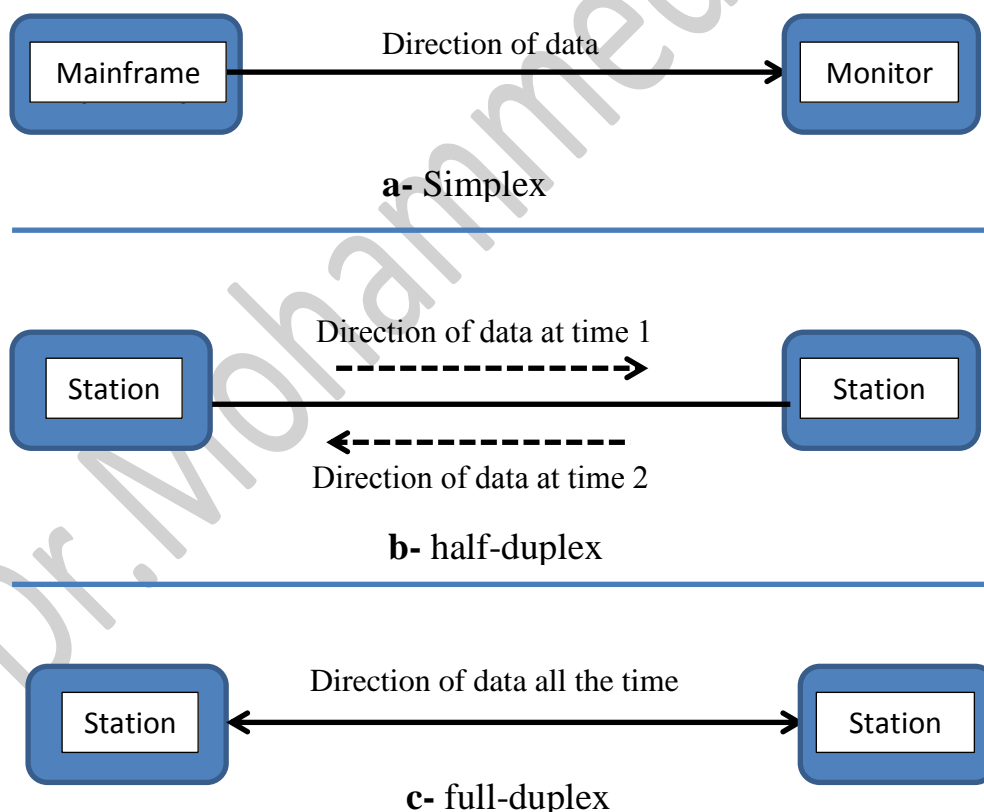

**Figure 1.2** Data flow (simplex, half-duplex, and full-duplex)

## 1.5 Networks

A network is a set of devices (often referred to as *nodes*) connected by communication links. A *node* can be a computer, printer, or any other device capable of sending and/or receiving data generated by other nodes on the network.

### 1.5.1 Distributed Processing

Most networks use distributed processing, in which a task is divided among multiple computers. Instead of one single large machine being responsible for all aspects of a process, separate computers (usually a personal computer or workstation) handle a subset.

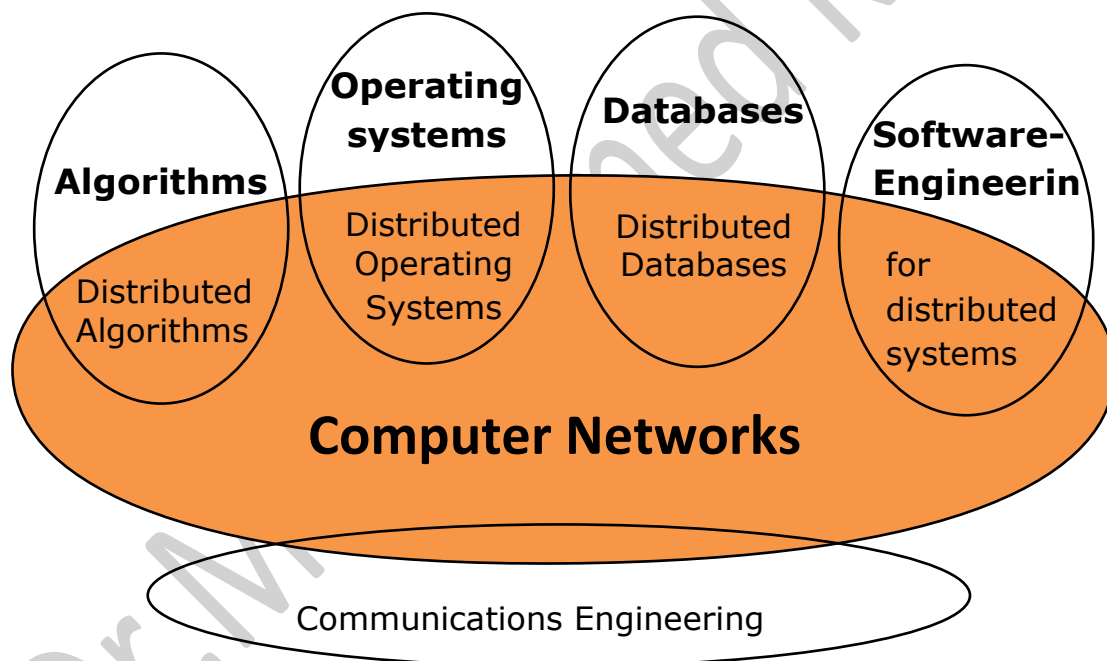

Figure 1.3 Distributed processing in computer networks vs. other Computer Science Classes

### 1.5.2 Types of Network Connections

There are two possible types of connections:

**Point-to-Point** This connection provides a dedicated link between two devices. The entire capacity of the link is reserved for transmission between those two

devices, (see Figure 1.3a). For example: establishing a point-to-point connection between the remote control and the television's control system.

**Multipoint** In this connection, more than two specific devices share a single link (see Figure 1.3b). The capacity of the channel is shared, either spatially or temporally. If several devices can use the link simultaneously, it is a *spatially shared* connection. If users must take turns, it is a *timeshared* connection.

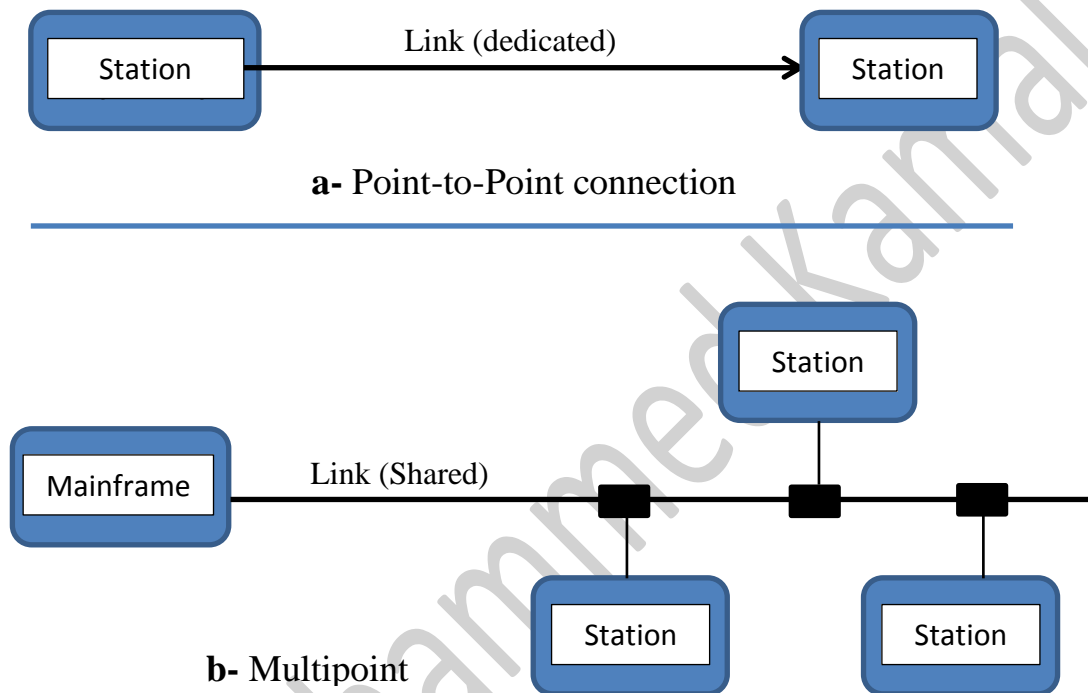

**Figure 1.3** *Types of connections: point-to-point and multipoint*

### 1.5.3 Physical Network Topology

The term *physical topology* refers to the way in which a network is arranged physically. There are four possible basic topologies:

**1. Mesh** In a mesh topology, every device has a dedicated point-to-point link to every other device.

**Advantages:**

- 1) Eliminating the traffic problems.
- 2) If one link becomes unusable, it does not fall the entire system.
- 3) High privacy or security.

**Disadvantages:**

- 1) Amount of cabling is required.
- 2) Number of I/O ports (e.g., LAN Cards) is required.

**Numbers of cables and hosts**

- Number of cables:  $n(n - 1) / 2$
- Number of ports:  $n(n - 1)$       **n**: number of hosts

**2. Star Topology** In a star topology, each device has a dedicated point-to-point link only to a central controller, usually called a **hub**. For example, the star topology is used in local-area networks (LANs).

**Advantages:**

- 1) Each device needs only one link and one I/O port to connect it.
- 2) Easy to install and reconfigure.

**Disadvantages:**

Single point dependency. If the hub goes down, the whole network is dead.

**Numbers of cables and hosts**

- Number of cables:  $1 \times n$
- Number of ports:  $1 \times n$       **n**: number of hosts

**Example:** Assume we have 5 hosts in Mesh and Star topologies. What the numbers of cables and ports are needed?

For Mesh Topology

- Number of cables:  $n(n - 1) / 2$   
 $5(5 - 1) / 2 = 10$  cables
- Number of ports:  $n(n - 1)$   
 $5(5 - 1) = 20$  ports

For Star Topology

- Number of cables:  $1 \times n = 5$  cables
- Number of ports:  $1 \times n = 5$  ports



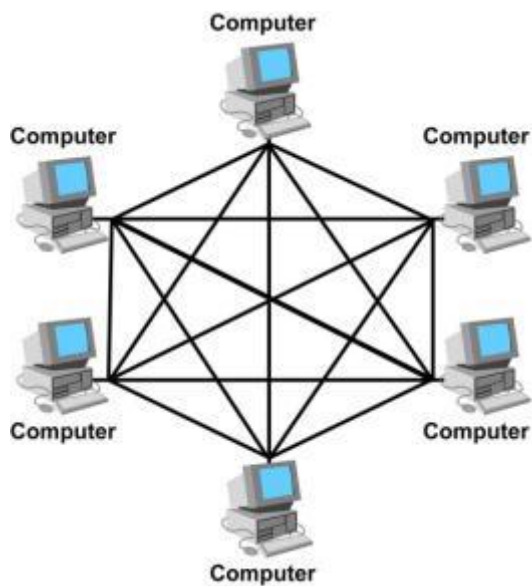

*Mesh network topology*

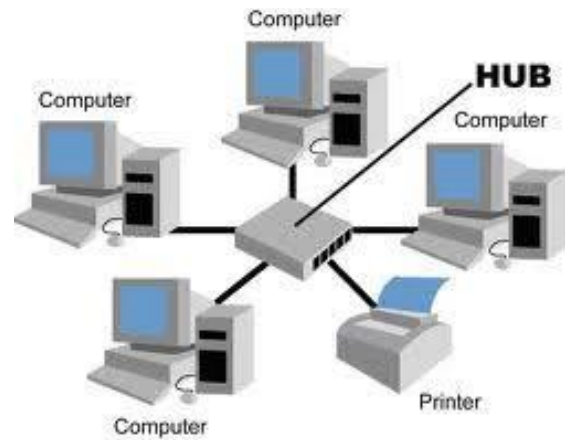

*Star network topology*

**3. Bus Topology** This topology is multipoint. One long cable acts as a backbone to link all the devices in a network. Nodes are connected to the bus cable by *drop lines* and *taps*.

**Advantages:**

- 1) Ease of installation.
- 2) Less cabling than mesh or star topologies.

**Disadvantages:** difficult reconnection and fault isolation.

**4. Ring Topology** Each device has a dedicated point-to-point connection with only the two devices on either side of it. A signal is passed along the ring in one direction, from device to device, until it reaches its destination.

**Advantages:**

Easy to install and reconfigure. Each device is linked to only its immediate neighbours (either physically or logically).

**Disadvantages:**

Unidirectional traffic i.e., a break in the ring (such as a disabled station) can disable the entire network.

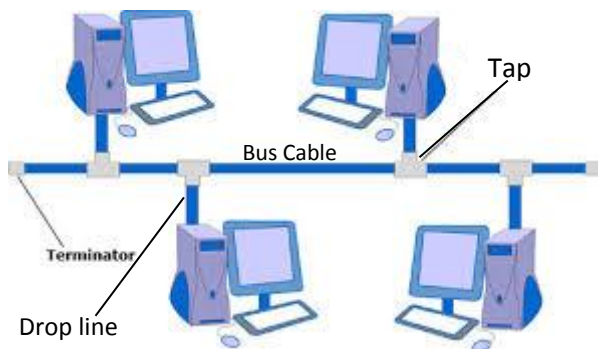

*Bus network topology*

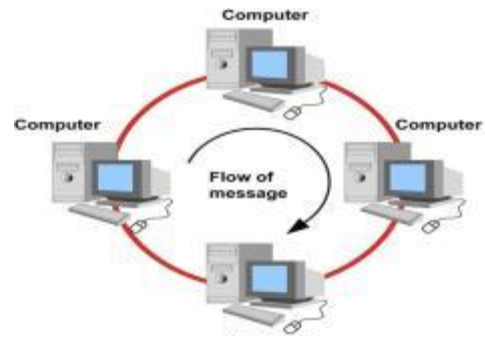

*Ring network topology*

**5. Hybrid Topology** A network can be hybrid. For example, we can have a main star topology with each branch connecting several stations in bus and ring topology.

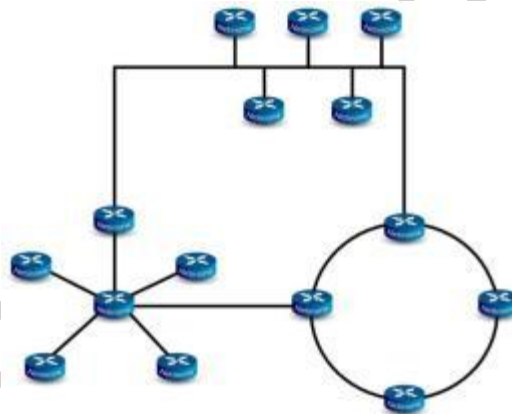

### 1.5.4 Categories of Networks

The category of networks is determined by its *size* and *connection type*. Figure 5 classifies the networks by their rough physical *size*.

<i>Distance</i>	<i>Location</i>	<i>Network category</i>
1 m	Square meter	Personal area network
10 m	Room	
100 m	Building	Local area network
1 km	Campus	
10 km	City	Metropolitan area network
100 km	Country	Wide area network
1000 km	Continent	
10,000 km	Planet	The Internet

**Figure 1.5** *Classification of networks by size*

**1. Personal Area Networks (PANs)** let devices communicate over the range of a person. A common example is a wireless network that connects a computer with its peripherals: monitor, keyboard, mouse, and printer. In the simplest form, Figure 6 shows a Bluetooth network uses the master-slave paradigm.

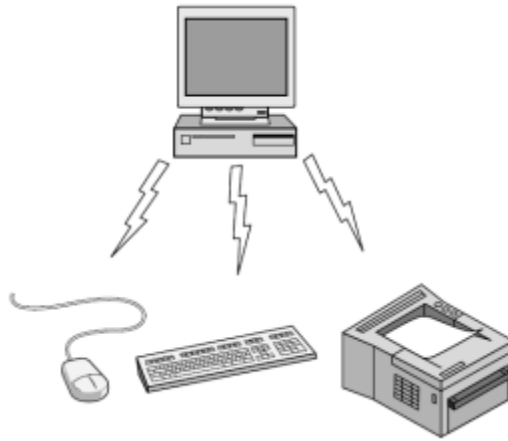

**Figure 1.6** *Bluetooth PAN Configuration*

**2. Local area networks (LANs)** link the devices in a single office, building, or campus (see Figure 1.7). LANs can be as simple as two PCs and a printer in someone's home office; or it can extend throughout a company, they are called *enterprise networks*.

*Wireless LANs* are very popular these days in which every computer has a radio modem (e.g., wireless LAN card) to communicate with other computers. Each computer talks to an *Access Point* or *wireless router* (see Figure 1-7a) to relay data packets between the wireless computers and also with the Internet. There is a standard for wireless LANs called *IEEE 802.11*, popularly known as *WiFi*. It runs at speeds from **11 to hundreds of Mbps**<sup>1</sup>.

*Wired LANs* use a range of different transmission technologies. Most of them use copper wires, but some use optical fibre. Typically, wired LANs run at **speeds of 100 Mbps to 1 Gbps**, have low delay (microseconds or nanoseconds), and make very few errors. Compared to wireless networks, wired LANs exceed them in all dimensions of performance. *IEEE 802.3*, popularly called *Ethernet*, is the most common type of wired LAN. Figure 1-7(b) shows a sample topology of switched Ethernet.

---

<sup>1</sup> The 1 Mbps (Megabits/sec) is 1,000,000 bits/sec, and the 1 Gbps (gigabits/sec) is 1,000,000,000 bits/sec.)

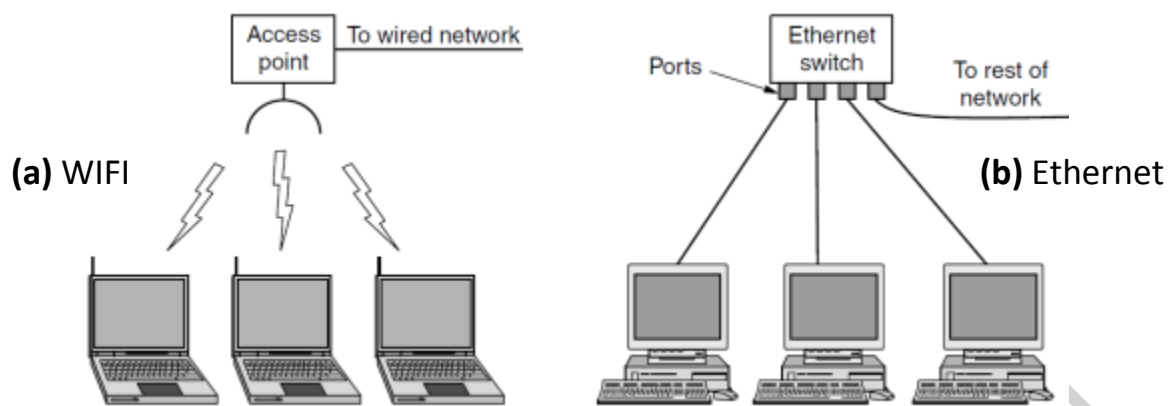

**Figure (1.7):** Wireless and wired LANs

**3. Metropolitan Area Network (MAN)** covers a city. The best-known examples of MANs are the cable television networks available in many cities. In Figure 1-8 we see both television signals and Internet being fed into the centralized cable head-end for subsequent distribution to people's homes.

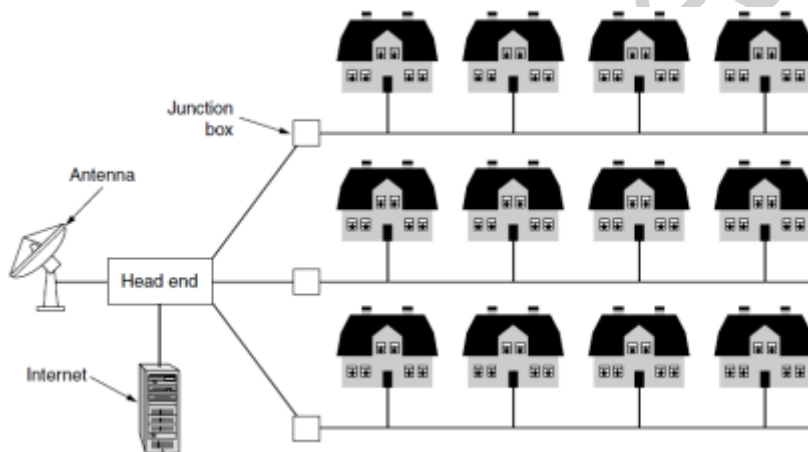
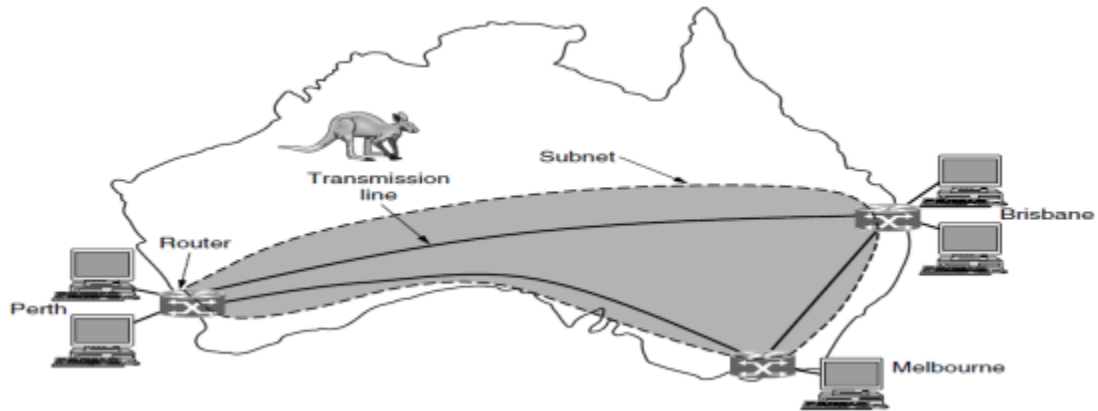

**Figure 1.8** A metropolitan area network based on cable TV

**4. A wide area network (WAN)** provides long-distance transmission of data over large geographic areas that may comprise a country, a continent, or even the whole world.

The WAN in Figure 1-9 is a network in Australia that connects offices in Perth, Melbourne, and Brisbane. Each of these offices contains computer machines intended for running user (i.e., application) programs. Each of these machines are called host. The rest of the network that connects these hosts is then called the **communication subnet**, or just **subnet**<sup>2</sup> for short.

<sup>2</sup> There is second meaning for the word: **subnet** in conjunction with network addressing. We will discuss that meaning in next lecture.



**Figure 1.9:** WAN that connects three branch offices in Australia

## 5. Interconnection of Networks: Internetwork

Today, it is very rare to see a LAN, a MAN, or a WAN in isolation; they are connected to one another. When two or more networks with different hardware and software are connected, they become an *internetwork*, or *internet*. (i.e., it is a collection of interconnected networks). These terms is used in a generic sense, in contrast to the worldwide **Internet** (*which is one specific internet*), which we will always capitalize.

## 6. Internet

The Internet is a communication system that has brought a wealth of information to our fingertips and organized it for our use. The Internet today is not a simple hierarchical structure. It is made up of many wide- and local-area networks joined by connecting lines and switching devices (see Figure 1.10). The Internet uses the Internet service provider (ISP) networks to connect enterprise networks, home networks, and many other networks.

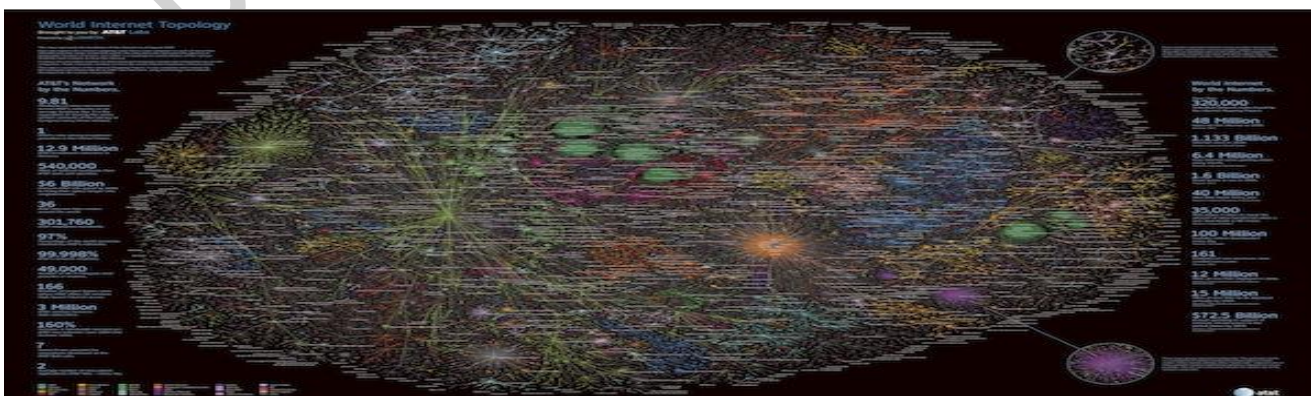

**Figure 1.10** Internet Map



Baghdad University  
Collage of Ibn-Al-Haitham for Pure  
Science  
Department of Computer Science



جامعة بغداد  
كلية التربية للعلوم الصرفة / ابن الهيثم  
قسم علوم الحاسبات

المرحلة الرابعة

صباحي + مسائي

(شبكات واتصالات - محاضرات النظرية)

ملزمة رقم 2

## Data communication and Networks

### Chapter 2: Network Standards and OSI Model

Dr. Mohammed Kamal Nsaif

Dr. Wisal Hashim Abdulsalam

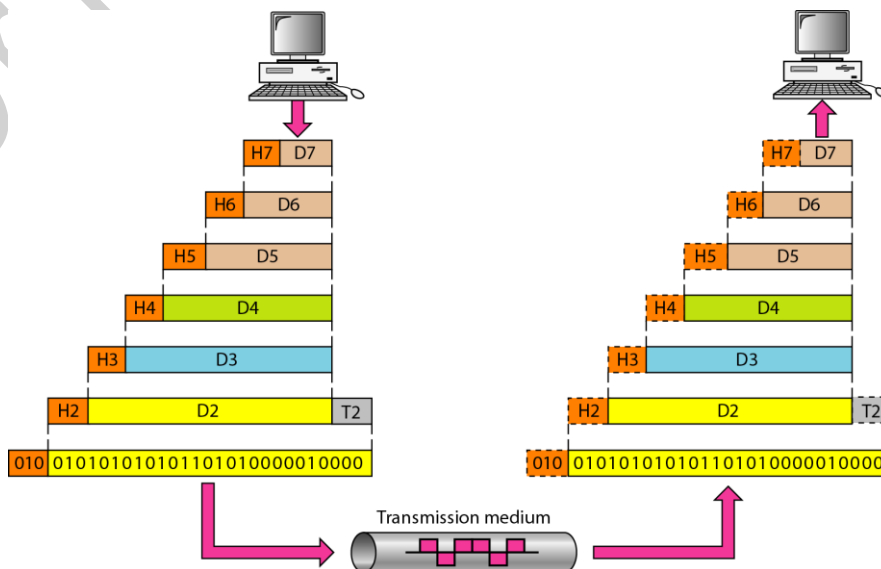

## 2.1 Network Criteria

A network must be able to meet a certain number of criteria. The most important of these are *performance*, *reliability*, and *security*.

*a) Performance* can be *measured* in many ways, including *transit time* and *response time*. **Transit time** is the amount of time required for a message to travel from one device to another. **Response time** is the elapsed time between an inquiry and a response.

The performance of a network **depends** on a number of *factors*:

- 1) Number of users.
- 2) Type of transmission medium.
- 3) Capabilities of the connected hardware.
- 4) Efficiency of the software.

Performance is often *evaluated* by two networking *metrics*: *throughput* and *delay*. We often need more *throughput* and *less delay*.

*b) Reliability* network reliability is measured by the:

- 1) Accuracy of delivery.
- 2) Frequency of failure.
- 3) The time it takes a link to recover from a failure.
- 4) Network's robustness in a catastrophe.

*c) Security* Network security issues include:

- 1) Protecting data from *unauthorized access*
- 2) Protecting data from *damage and change*.
- 3) Implementing policies for recovery from data losses.

## 2.2. Protocols and Standards

### A) Protocol

A protocol defines *what* is communicated, *how* it is communicated, and *when* it is communicated. The *key elements* of a protocol are syntax, semantics, and timing.

**Syntax** It refers to the *structure or format* of the data, meaning the order in which they are presented.



*For example*, a simple protocol might expect the first 8 bits of data to be the address of the sender, the second 8 bits to be the address of the receiver, and the rest of the stream to be the message itself.

**Semantics** It refers to the meaning of each section of bits. How is a particular pattern to be interpreted, and what action is to be taken based on that interpretation?

*For example*, does an address identify the route to be taken or the final destination of the message?

**Timing** It refers to two characteristics: *when* data should be sent and *how fast* they can be sent.

*For example*, if a sender produces data at 100 Mbps but the receiver can process data at only 1 Mbps, the transmission will overload the receiver and some data will be lost.

## **B) Standards**

Standards are essential in creating an open and competitive market for equipment manufacturers and in guaranteeing national and international telecommunications.

### ***Standards Creation Committees***

Most data telecommunications rely primarily on the standards published by the following committees:

- *International Organization for Standardization (ISO).*
- *American National Standards Institute (ANSI).*
- *Institute of Electrical and Electronics Engineers (IEEE).*
- *Electronic Industries Association (EIA).*

## **2.3 Network Models**

The layered model that dominated data communications and networking literature before 1990 was the *Open Systems Interconnection (OSI)* model. Everyone believed that the OSI model would become the ultimate standard for data communications, but this did not happen. *The TCP/IP protocol suite became the dominant commercial architecture because* it was used and tested extensively in the Internet; *the OSI model was never fully implemented.*

The *Open Systems Interconnection (OSI)* model is introduced in the late 1970s by the *International Standards Organization (ISO).*

(**Note:** ISO is the organization. OSI is the model.)



**The OSI model** is a layered model for the design and understands of network systems that allows communication between all types of computer systems.

OSI consists of seven separate but related layers, each of which defines a part of the process of moving information across a network (*see Figure 2.1*). When a message is sent *for example* from device **A** to device **B**. As the message travels from A to B, it may pass through many intermediate nodes, **called routers**. These *intermediate nodes usually involve only the first three layers* of the OSI model.

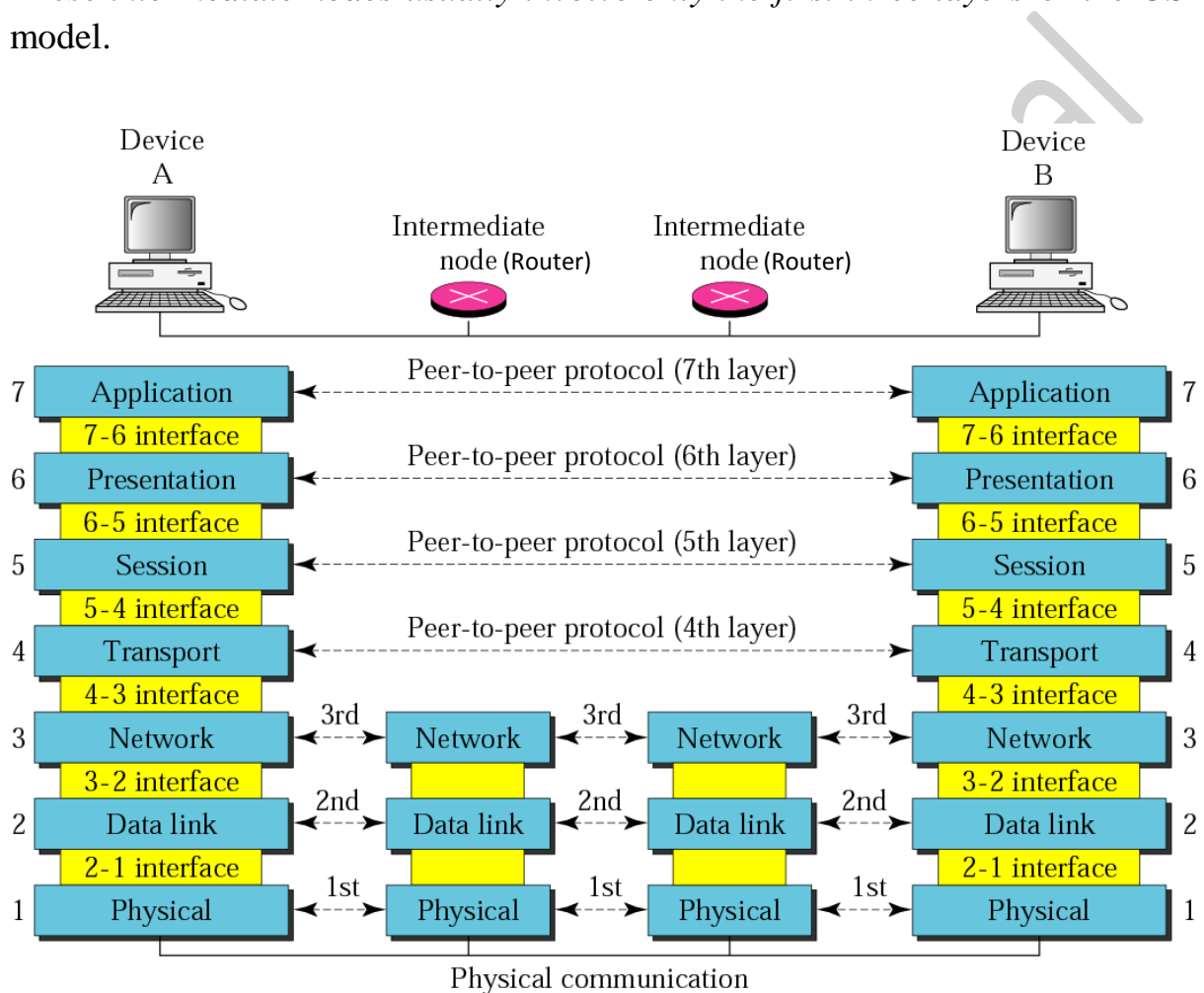

**Figure 2.1** The interaction between layers in the OSI model

Each layer defines a family of functions distinct from those of the other layers. Each layer at the sending site uses the services of the layer immediately below it. The sender at the higher layer uses the services of the middle layer. The middle layer uses the services of the lower layer. The lower layer uses the services of the carrier. Layer 3, for example, uses the services provided by layer 2 and provides services for layer 4.

The processes on each machine that communicate at a given layer are called *peer-to-peer processes*. Communication between machines is therefore a peer-to-peer process using the protocols appropriate to a given layer.

The **interfaces** between layers are to define the *information and services* that each layer must provide for the layer above it.

The seven layers are belonging to three subgroups. Layers 1, 2, and 3 are the network support layers; they deal with the physical aspects of moving data from one device to another (such as electrical specifications, physical connections, and physical addressing). Layers 5, 6, and 7 are the user support layers; they allow interoperability among unrelated software systems. Layer 4, the transport layer, links the two subgroups.

### 2.3.1 Layers in the OSI Model

In the following we describe the functions of each layer in the OSI model.

#### 1. Physical Layer

The physical layer coordinates the functions required to carry a bit stream over a physical medium (see Figure 2.2).

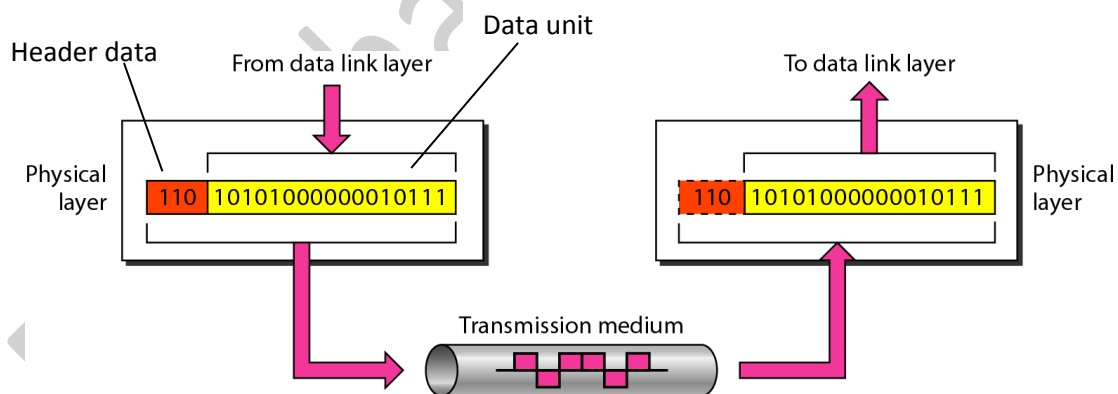

**Figure 2.2** Physical layer

The physical layer is concerned with the following:

- Physical characteristics of interfaces and medium.

- Representation of bits (sequence of 0s or 1s) with defining the type of encoding (how 0s and 1s are changed to signals).
- Data rate or the transmission rate (the number of bits sent each second)
- Synchronization of bits. The sender and receiver not only must use the same bit rate but also must be synchronized at the bit level.
- Line configuration (point-to-point or multipoint configuration).
- Physical topology (mesh, star, bus, etc.).
- Transmission mode (simplex, half-duplex, or full-duplex).

## 2. Data Link Layer

The data link layer makes the physical layer appear error-free to the upper layer (network layer). Figure 2.3 shows the relationship of the data link layer to the network and physical layers.

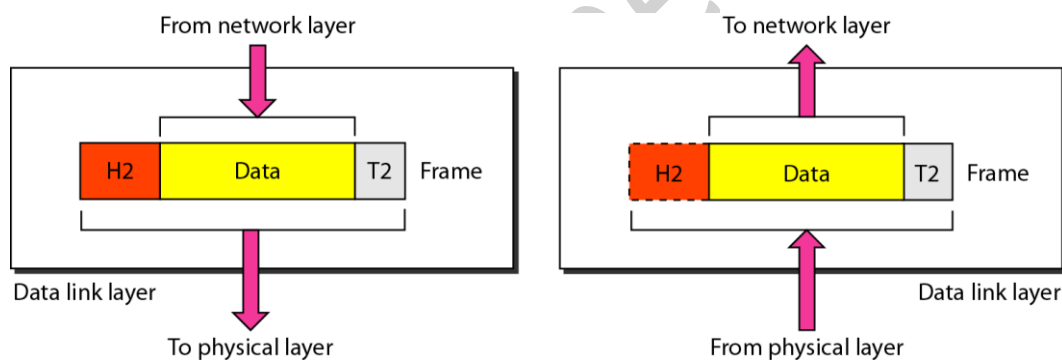

**Figure 2.3** Data Link layer

The data link layer is responsible for moving frames from one hop (node) to the next. Other responsibilities of the data link layer include the following:

- Framing. The data link layer divides the stream of bits received from the network layer into manageable data units called **frames** (see Figure 2.3).
- Physical addressing. The data link layer adds a header to the frame to define the sender and/or receiver devices of the frame. The devices are defined by the physical address (or MAC address).
- Flow control. The data link layer ensures the rate at which data are produced in the sender and arrived in the receiver.

- Error control. The data link layer adds mechanisms to detect and retransmit damaged or lost frames. Error control is normally achieved through a **trailer** added to the end of the frame (see the **T2** in Figure 2.3).
- Access control. The data link layer controls the access to the link when two or more devices are connected to the same link.

### 3. Network Layer

The network layer is responsible for the **source-to-destination delivery** of a **packet** (see Figure 2.4), possibly across multiple networks (links). Whereas the data link layer oversees the delivery of the packet between two systems *on the same* network (links).

Other responsibilities of the network layer include the following:

- Logical addressing. The network layer adds a header to the packet coming from the upper layer that, among other things, includes the logical addresses (**IP address**) of the sender and receiver.
- Routing. When independent networks or links are connected to create internetworks, the connecting devices (called routers or switches) route or switch the packets to their final destination. One of the functions of the network layer is to provide this mechanism.

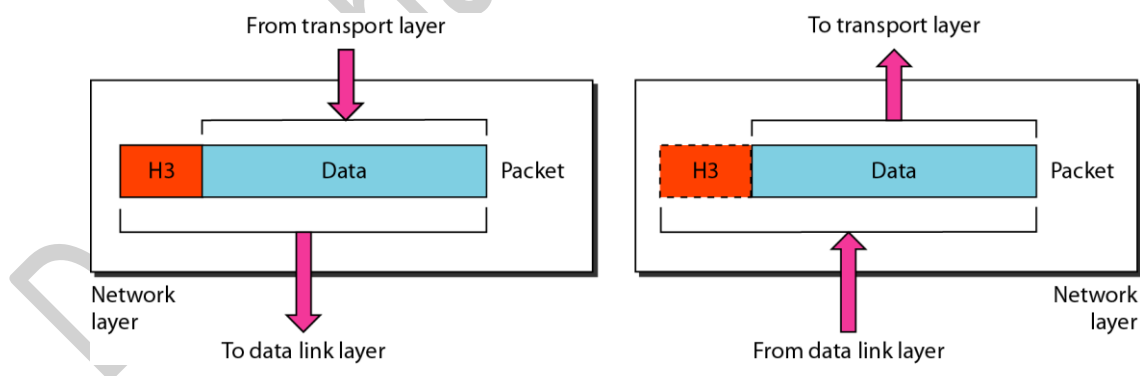

**Figure 2.4** Network layer

## 4. Transport Layer

The transport layer is responsible for **process-to-process delivery** of the entire message. A process is an application program running on a host. Whereas the network layer oversees source-to-destination delivery of individual packets.

Other responsibilities of the transport layer include the following:

- Service-point addressing. Computers often run several programs at the same time. The transport layer header includes a type of address called a service-point address (or **port address**) *in order to deliver the entire message to the correct process on that computer.*
- Segmentation and reassembly. A message is divided into transmittable segments, with each segment containing a sequence number. These numbers enable the transport layer to reassemble the message correctly at the destination (see Figure 2.5).
- Flow control. Like the data link layer, the transport layer is responsible for flow control. However, flow control at this layer is performed end to end rather than across a single link.
- Error control. Like the data link layer, the transport layer is responsible for error control. However, error control at this layer is performed process-to-process rather than across a single link.

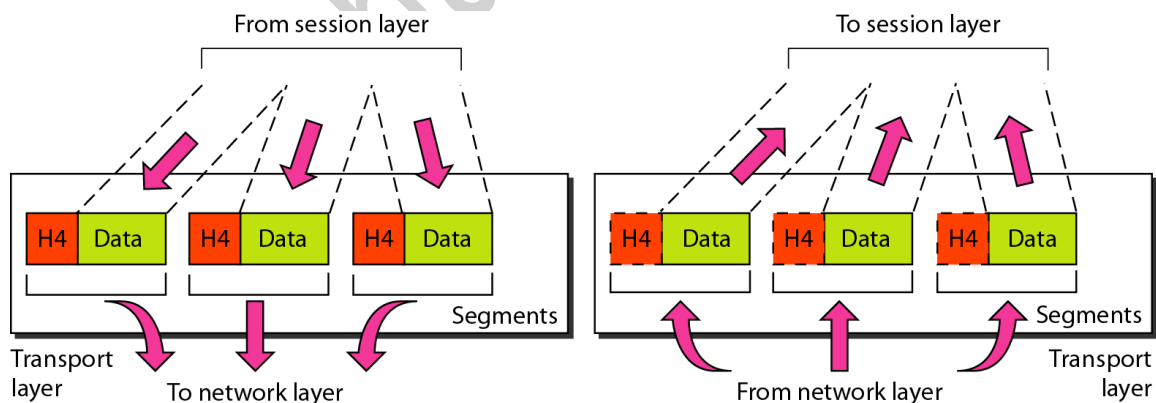

**Figure 2.5** Transport layer

## 5. Session Layer

The services provided by the first three layers (physical, data link, and network) are not sufficient for some processes. The session layer is responsible for dialog control and synchronization.

Specific responsibilities of the session layer include the following:

- Dialog control. The session layer allows the communication between two processes to take place in either half-duplex (one way at a time) or full-duplex (two ways at a time) mode.
- Synchronization. The session layer allows a process to add checkpoints, or synchronization points, to a stream of data (see Figure 2.6). For example, if a system is sending a file of 2000 pages, it is advisable to insert checkpoints after every 100 pages.

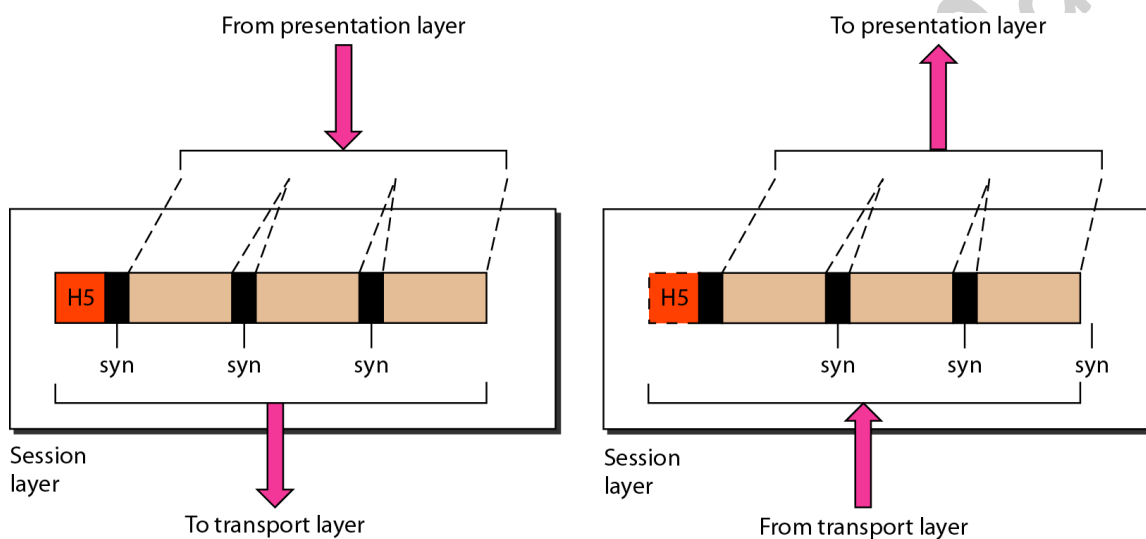

Figure 2.6 Session layer

## 6. Presentation Layer

The presentation layer is concerned with the syntax and semantics of the information exchanged between two systems (see Figure 2.7).

Specific responsibilities of the presentation layer include the following:

- Translation. Because different computers use different encoding systems, the presentation layer is responsible for interoperability between these different encoding methods.
- Encryption. To carry sensitive information, a system must be able to ensure privacy.
- Compression. Data compression **reduces** the number of bits contained in the information. Data compression becomes particularly important in the data transmission.

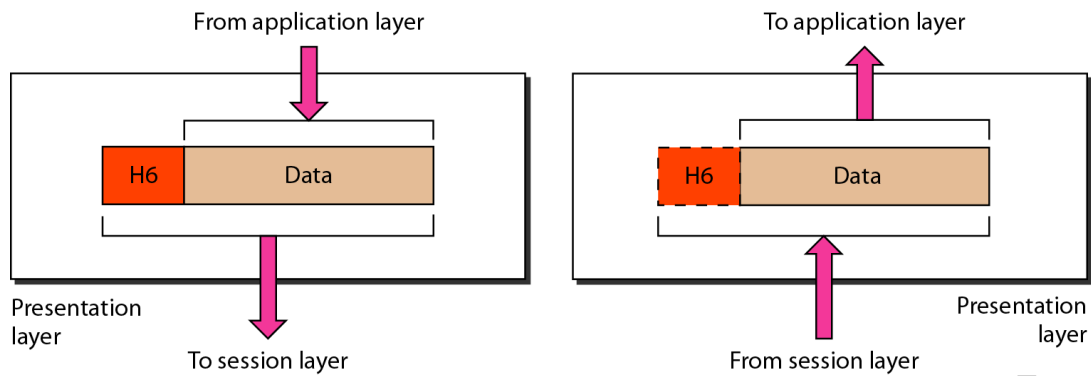

**Figure 2.7** Presentation layer

## 7. Application Layer

The application layer is responsible for providing services to the user. It enables the user, whether human or software, to access the network. It provides user interfaces and support for services such as electronic mail, remote file access and transfer, and other types of distributed information services.

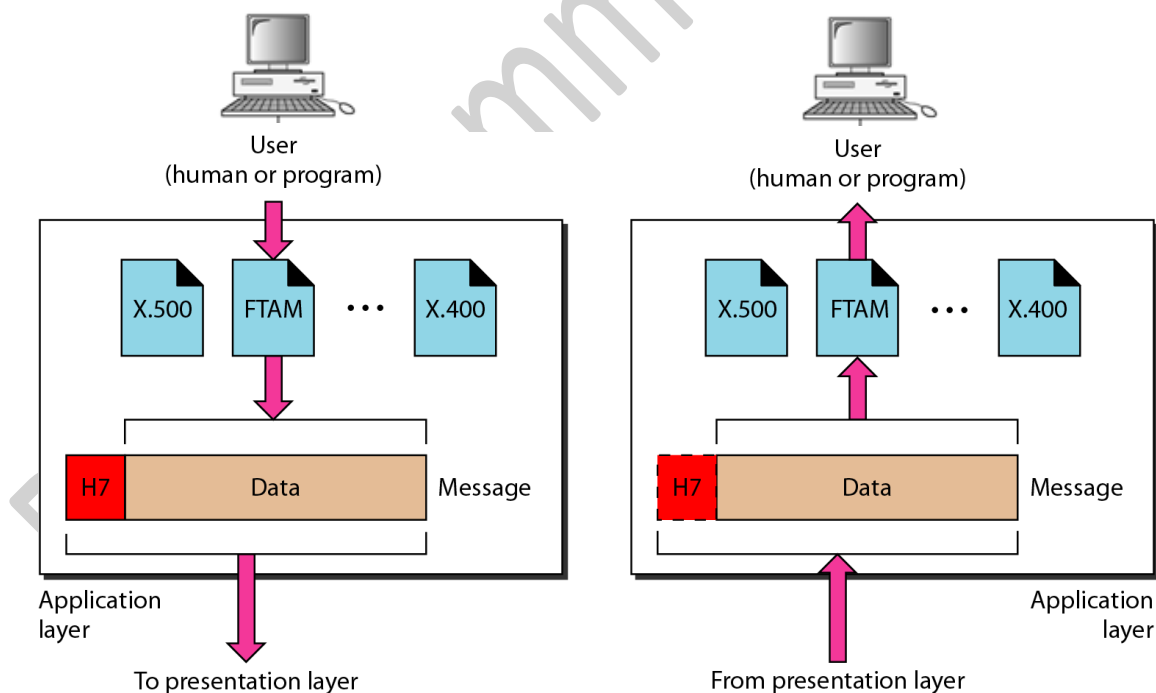

**Figure 2.8** Application layer

## Summary of OSI Layers

Figure 2.9 shows a summary of duties for each layer in the OSI model.

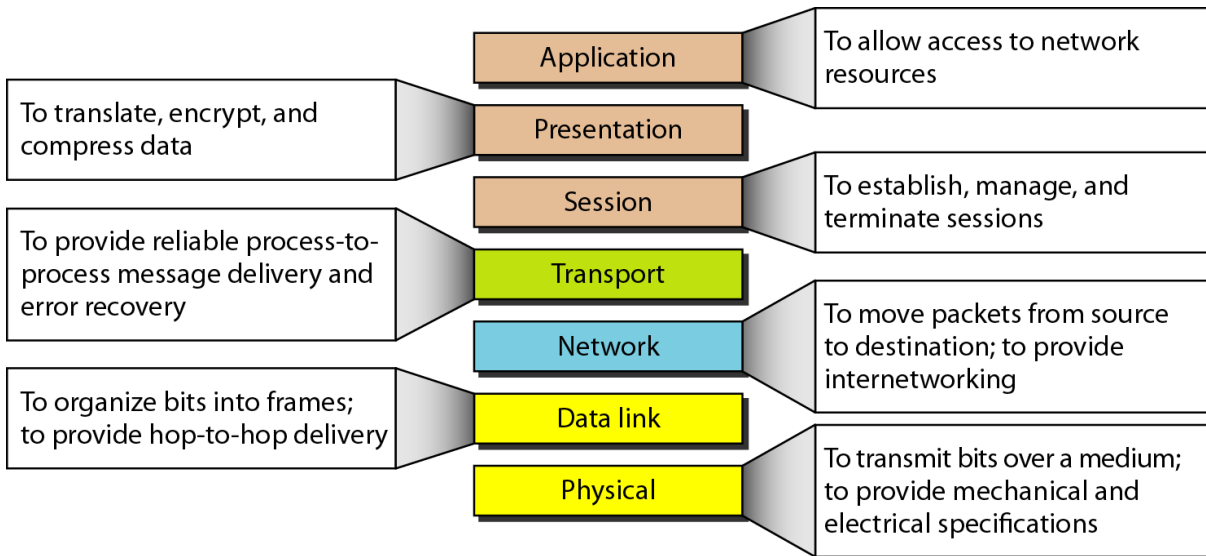

**Figure 2.9** Summary of OSI layers





Baghdad University  
Collage of Ibn-Al-Haitham for Pure  
Science  
Department of Computer Science



جامعة بغداد  
كلية التربية للعلوم الصرفة / ابن الهيثم  
قسم علوم الحاسبات

المرحلة الرابعة

صباحي + مسائي

(شبكات واتصالات - محاضرات النظري)

ملزمة رقم 3

## Data communication and Networks

### Chapter 3: TCP/IP Protocol Suite and addressing

Dr. Mohammed Kamal Nsaif

Dr. Wisal Hashim Abdulsalam

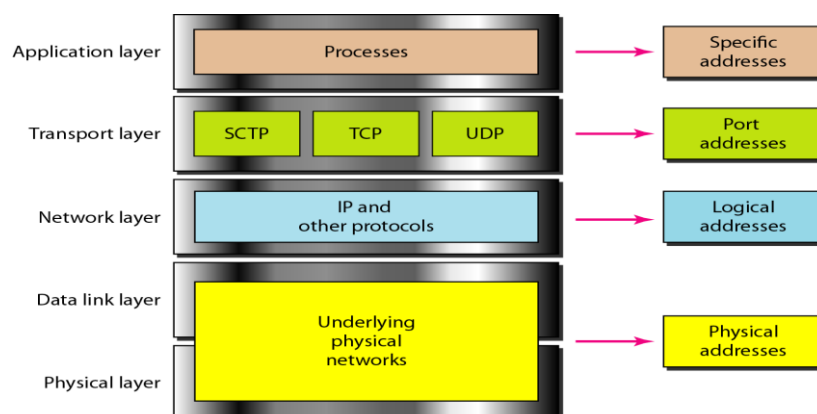

## 3.1 TCP/IP Protocol Suite

The TCP/IP protocol suite is made of four layers: physical & data link which called link layer, network (or Internet layer), transport, and application. It developed by Defence Advanced Research Project Agency (DARPA). The first four layers provide physical standards, network interfaces, internetworking, and transport functions that correspond to the first four layers of the OSI model (see Figure 3.1). The three topmost layers in the OSI model, however, are represented in TCP/IP by a single layer called the *application layer*.

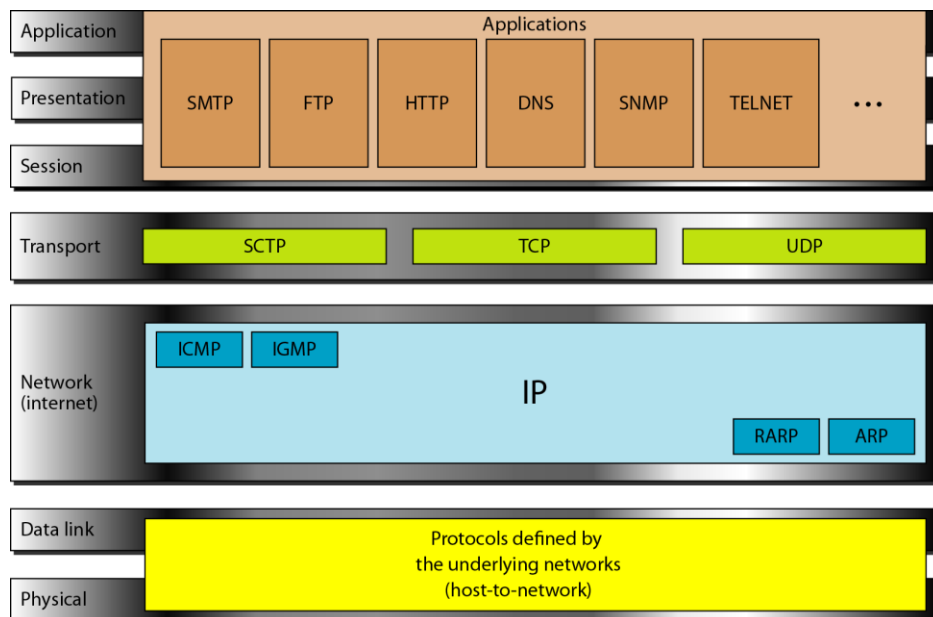

Figure 3.1 TCP/IP and OSI Model

### 1. Physical and Data Link Layers

At the physical and data link layers, *TCP/IP* does not define any specific protocol. It supports all the standard and proprietary protocols. A network in a *TCP/IP* internetwork can be a local-area network or a wide-area network.

### 2. Network Layer

At the network layer (or the internetwork layer), *TCP/IP* supports the Internetworking Protocol (IP). IP uses four supporting protocols: ARP, RARP, ICMP, and IGMP as described in the following:

The **Internetworking Protocol (IP)** is the transmission mechanism used by the TCP/IP protocols. IP transports data in packets called *datagrams*, each of which is transported separately. Datagrams can travel along different routes and can arrive out of sequence or be duplicated.

The **Address Resolution Protocol (ARP)** is used to associate a logical address with a physical address. ARP is used to find the physical address of the node when its Internet address is known.

The **Reverse Address Resolution Protocol (RARP)** allows a host to discover its Internet address when it knows only its physical address. It is used when a computer is connected to a network for **the first time**.

The **Internet Control Message Protocol (ICMP)** is a mechanism used by hosts and gateways to send notification of datagram problems back to the sender.

The **Internet Group Message Protocol (IGMP)** is used to facilitate the simultaneous transmission of a message to a group of recipients.

### 3. Transport Layer

The main protocols in transport layer are the TCP and UDP. IP protocol in network layer is a **source-to-destination** protocol, meaning that it can deliver a packet from one physical device to another. UDP and TCP are transport level protocols responsible for delivery of a message from a process (running program) to another process (**process-to-process** protocols).

The **User Datagram Protocol (UDP)** is the simpler of the two standard TCP/IP transport protocols. It is a process-to-process protocol that adds only **port addresses, checksum error control, and length information** to the data from the upper layer.

The **Transmission Control Protocol (TCP)** is a **reliable stream** transport protocol. The term *stream*, in this context, means **connection-oriented**: A connection must be established between both ends of a transmission before either can transmit data.

At the sending end of each transmission, TCP divides a stream of data into smaller units called *segments*. Each segment includes a sequence number for reordering after receipt. At the receiving end, TCP collects each datagram as it comes in and reorders the transmission based on sequence numbers.

**The Stream Control Transmission Protocol (SCTP)** provides support for newer applications such as voice over the Internet.

## 4. Application Layer

The application layer in TCP/IP is **equivalent** to the combined **session, presentation, and application** layers in the OSI model. Many protocols are defined at this layer.

## 3.2 Addressing

Four levels of addresses are used in an internet employing the TCP/IP protocols: **physical (link) addresses, logical (IP) addresses, port addresses, and specific addresses** (see Figure 3.2).

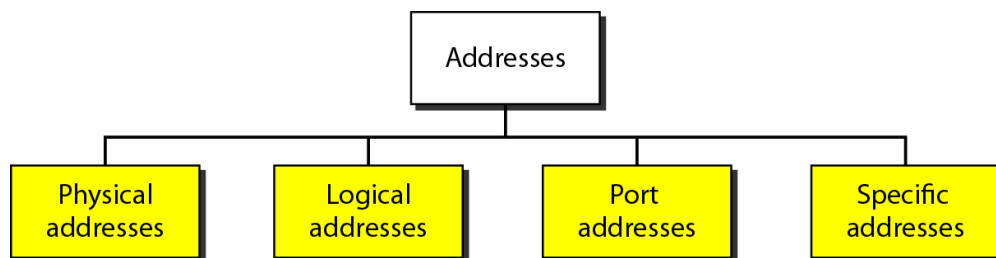

**Figure 3.2** Addressing in TCP/IP

Each address is related to a specific layer in the TCP/IP architecture, as shown in Figure 3.3.

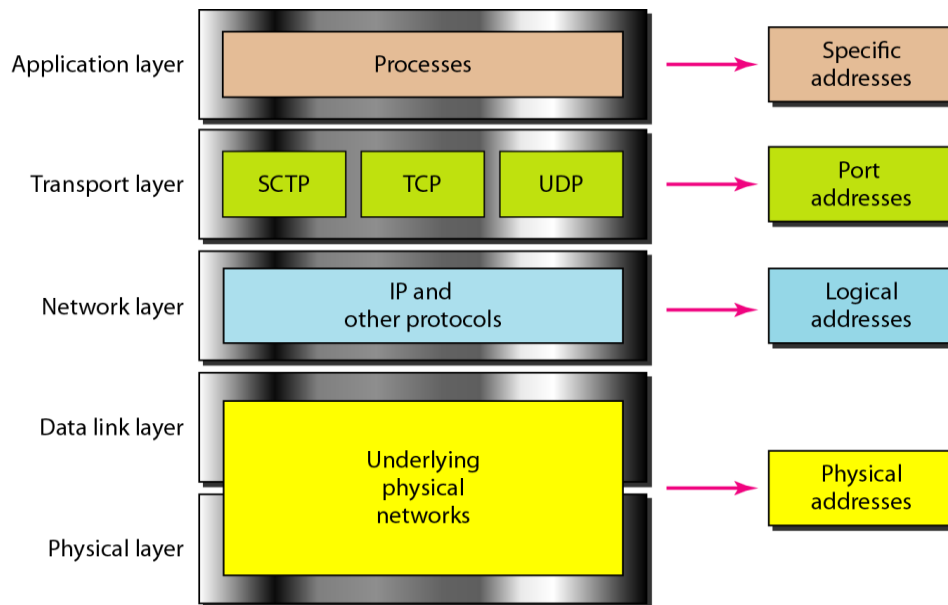

**Figure 3.3** Relationship of layers and addresses in TCP/IP

### 3.2.1 Physical Addresses

The physical address, also known as the link address, is the address of a node as defined by its LAN or WAN. It is included in the frame used by the data link layer. It is the lowest-level address.

#### Example 1

In Figure 3.4 a node with physical address 10 sends a frame to a node with physical address 87. The two nodes are connected by a link (bus topology LAN). At the data link layer, this frame contains physical (link) addresses in the header. These are the only addresses needed. The data link layer at the sender receives data from an upper layer. It encapsulates the data in a frame, adding a header and a trailer.

**Encapsulation** means that a packet (header, data and maybe trailer) at a specific level is encapsulated in one whole packet.

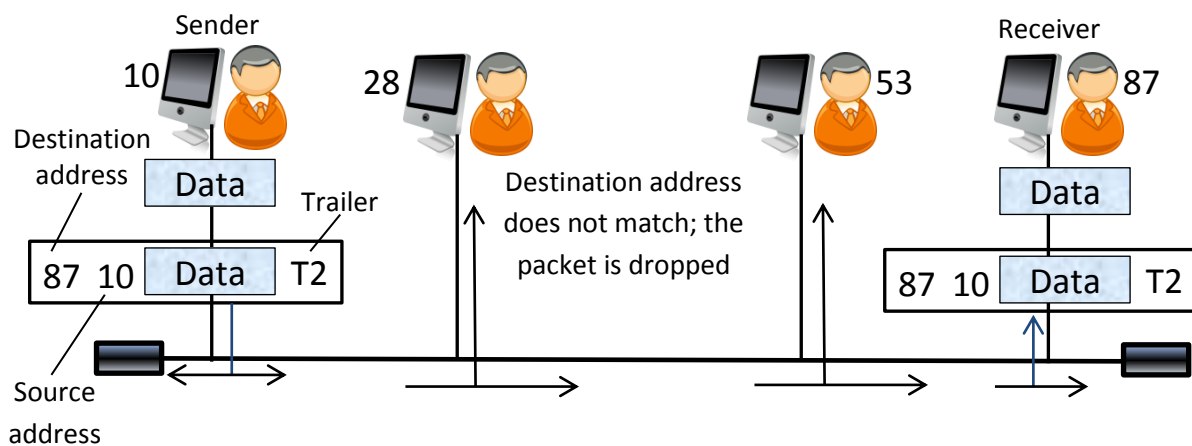

**Figure 3.4** Example of physical addresses

Most local-area networks use a **48-bit (6-byte)** physical address written as **12 hexadecimal digits**; every byte (2 hexadecimal digits) is separated by a colon, as shown below:

07:01:02:01:2C:4B

A 6-byte (12 hexadecimal digits) physical address

The physical address is imprinted on the network interface card (NIC) as shown in the left picture and can be displayed on any computer as shown in the right screenshot.

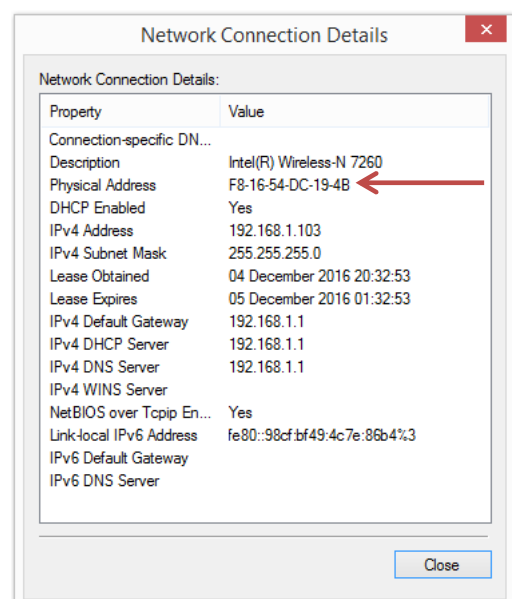

A screenshot that shows a physical address and other connection details

## 3.2.2 Logical Addresses

Physical addresses are not enough in an internetwork environment. A universal (or logical) addressing system is needed in which each host can be identified uniquely, regardless of the underlying physical network.

A logical address in the Internet is currently a 32-bit address that can uniquely define a host connected to the Internet. No two publicly addressed hosts on the Internet can have the same IP address.

**192.168.1.100**  
**IP (or logical) address, Version 4, Class C**

### Example 2

Figure 3.6 shows a part of an internet with two routers connecting three LANs. Each device (computer or router) has a pair of addresses (logical and physical). The computer with **logical address A** and **physical address 10** needs to send a packet to the computer with **logical address P** and **physical address 95**.

The sender encapsulates its data in a packet at the network layer and adds two logical addresses (A and P). The network layer, however, needs to find the physical address of the next hop before the packet can be delivered. The network layer consults its **routing table** and finds the logical address of the next hop (router 1) to be F. The **ARP** finds the physical address of router 1 that corresponds to the logical address of 20. Now the network layer passes this address to the data link layer, which in turn encapsulates the packet with physical destination address 20 and physical source address 10.

Since the logical destination address does not match the router's logical address, the router 1 knows that the packet needs to be forwarded to router 2. When the frame reaches the destination, the packet is de-capsulated. The destination logical address P matches the logical address of the computer. The data are de-capsulated from the packet and delivered to the upper layer.

**Note:** Although physical addresses will **change from hop to hop**, logical addresses **remain the same** from the source to destination (but there are some exceptions to this rule).

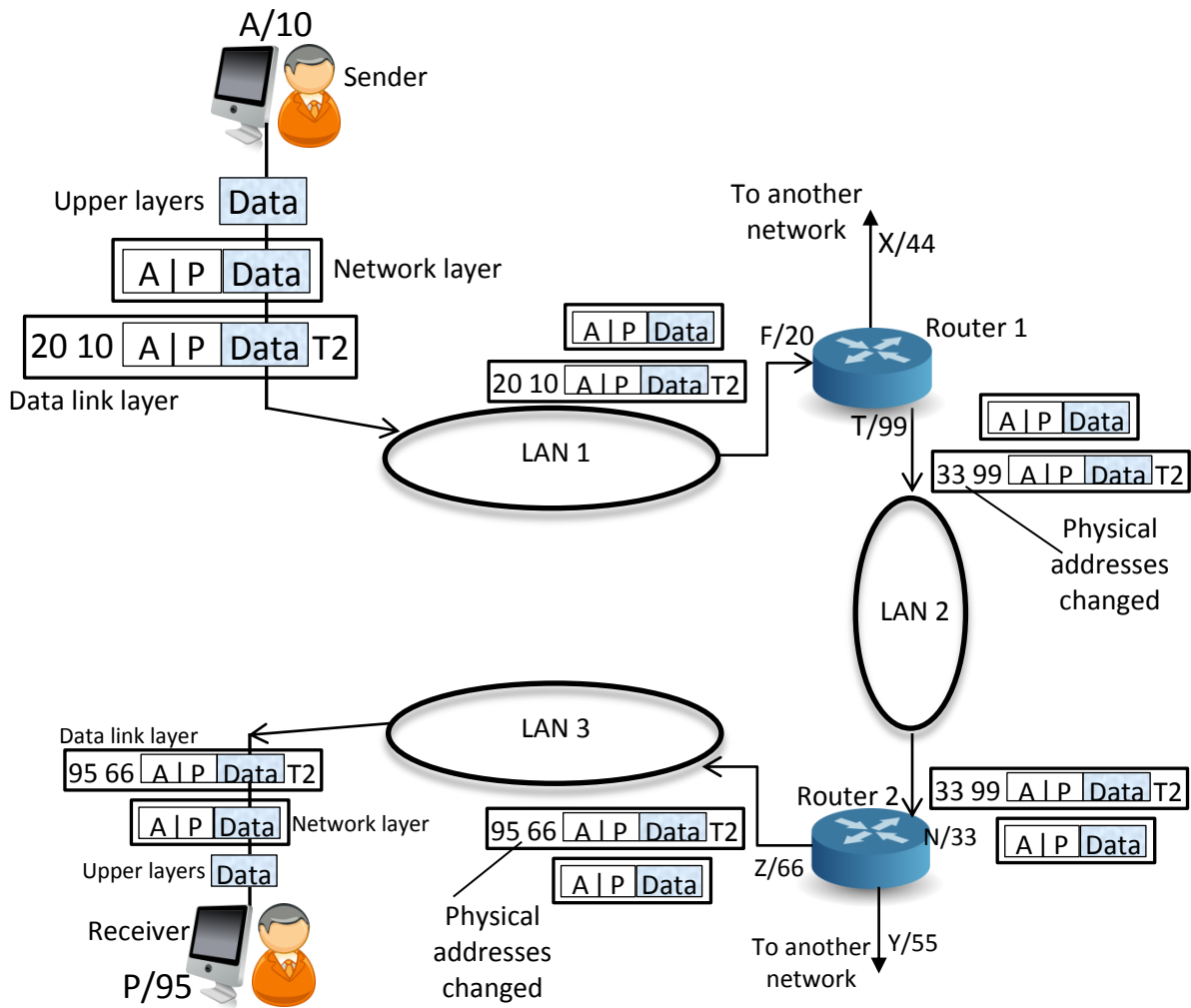

**Figure 3.6** Example of logical (IP) addresses

### 3.2.3 Port Addresses

Today, computers are devices that can run multiple processes at the same time. The end objective of Internet communication is a process communicating with another process. Therefore, we need a method to label the different processes. In the TCP/IP architecture, the label assigned to a process is called a **port address**. A port address in TCP/IP is 16 bits in length.

#### Example 3

Figure 3.7 shows two computers communicating via the Internet. The sending computer is running three processes at this time with port addresses (a), (b), and (c). The receiving computer is running two processes at this time with port addresses (j) and (k). Process (a) in the sending computer needs to communicate



with process (j) in the receiving computer. Note that although both computers are using the same application, FTP, for example, the port addresses are different **because** one is a **client program** and the other is a **server program**.

**Note:** Although **physical addresses** change from hop to hop, **logical and port addresses** remain the same from the source to destination (there are some exceptions to this rule).

### 3.2.4 Specific Addresses

Some applications have user-friendly addresses that are designed for that specific address, for example:

- The e-mail address (for example, someone@gmail.com) that defines the recipient of an e-mail.
- Universal Resource Locator (**URL**) (for example, www.google.com) that is used to find a document on the *World Wide Web* (WWW).

The e-mail and URL addresses **are changed** automatically to the corresponding **port and logical addresses** by the sending computer (**by using the DNS: Domain Name System**).

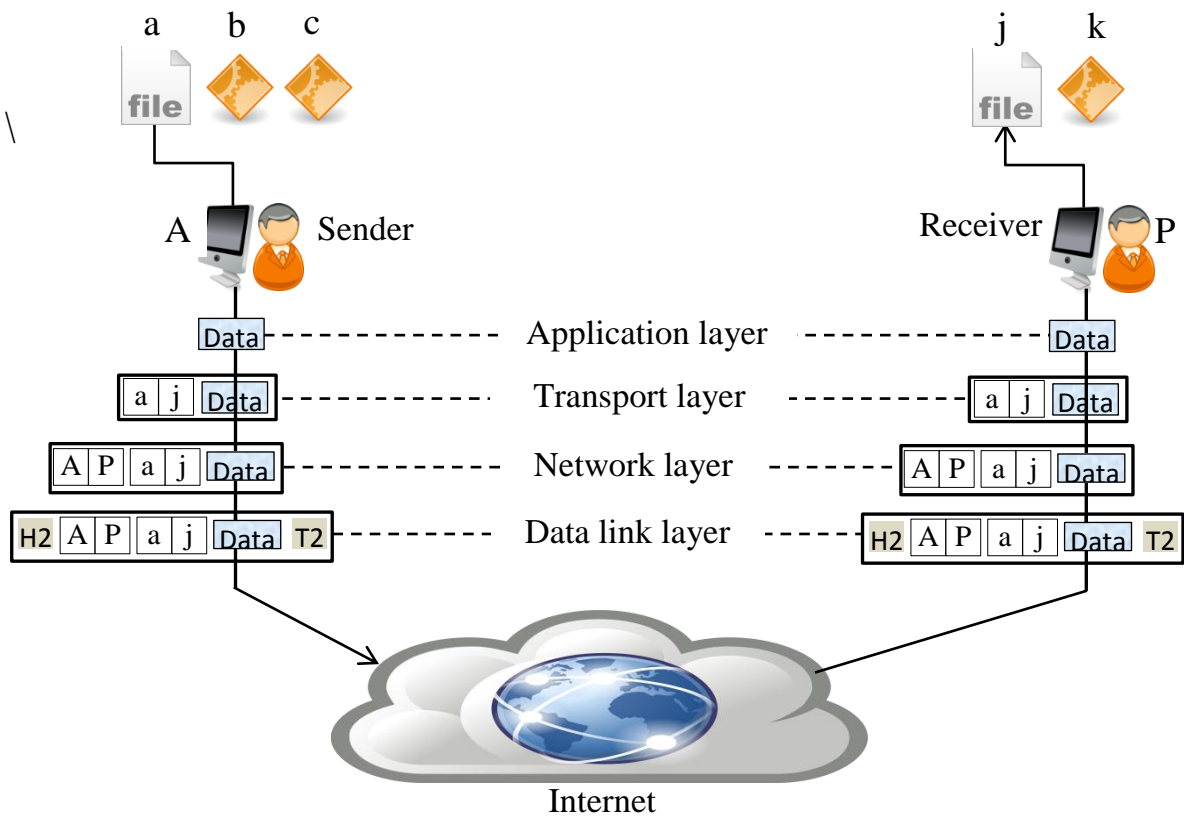

**Figure 3.7** Example of port addresses

According to the function of each layer, **the encapsulation operation** of the above figure is included the following:

- The transport layer **encapsulates** data from the application layer in a **packet** and adds two port addresses (a) and (j), source and destination.
- The packet from the transport layer is then **encapsulated** in another **packet** at the network layer with logical source and destination addresses (A and P).
- Finally, the packet is **encapsulated** in a **frame** with the physical source and destination addresses of the next hop.



Baghdad University  
Collage of Ibn-Al-Haitham for Pure  
Science  
Department of Computer Science



جامعة بغداد  
كلية التربية للعلوم الصرفة / ابن الهيثم  
قسم علوم الحاسبات

المرحلة الرابعة

صباحي + مسائي

(شبكات واتصالات - محاضرات النظري)

ملزمة رقم 4

## Data communication and Networks

### Chapter 4: Data and Analog Signals

Dr. Mohammed Kamal Nsaif

Dr. Wisal Hashim Abdulsalam

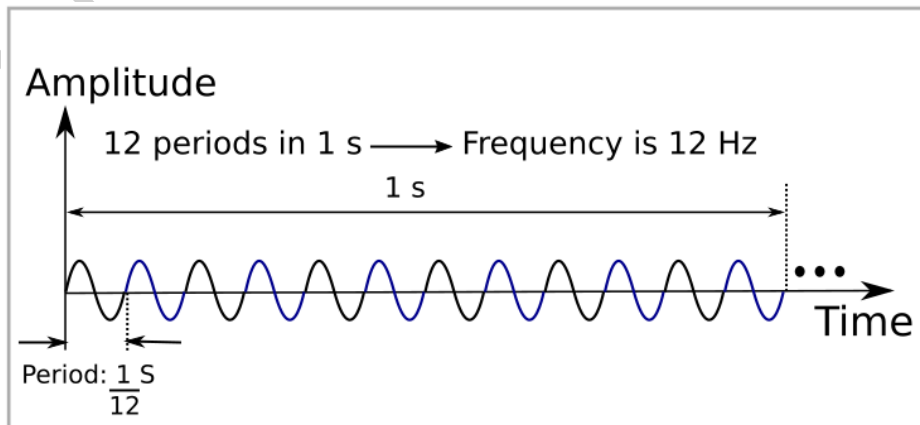

## 4. Data and Signals

One of the major functions of the *physical layer* is to move data in the form of electromagnetic signals across a transmission medium. Generally, the data usable to a person or application are not in a form that can be transmitted over a network. For example, a photograph must first be changed to a form that transmission media can accept. Transmission media work by conducting energy along a physical path.

### 4.1 Analog and Digital Data

Data can be analog or digital. The term analog data refers to information that is continuous; digital data refers to information that has discrete states.

Digital data take on discrete values. For example, data are stored in computer memory in the form of 0s and 1s. They can be converted to a digital signal or modulated into an analog signal for transmission across a medium.

Then **Analog data** are continuous and take continuous values. **Digital data** have discrete states and take discrete values.

### 4.2 Analog and Digital Signals

Like the data they represent, signals can be either analog or digital. An **analog signal** can have an infinite number of values in a range over a period of time. A **digital signal**, on the other hand, can have only a limited number of defined values, it is often as simple as 1 and 0.

**Figure 3.1 illustrates an analog signal and a digital signal.** The vertical axis represents the value or strength of a signal. The horizontal axis represents time.

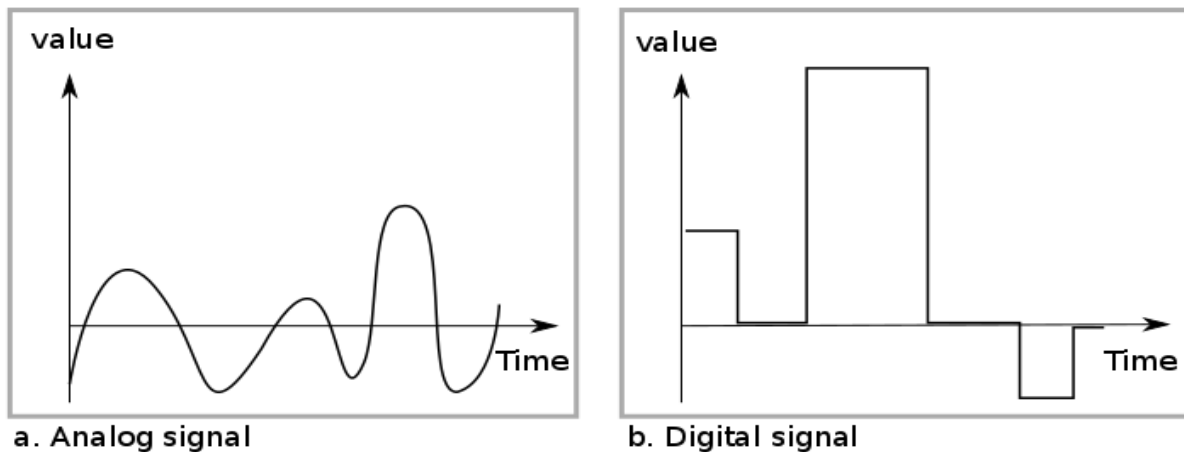

Figure 4.1 Comparison of analog and digital signals

## Periodic and Non-periodic Signals

A **periodic signal** completes a pattern within a measurable time frame, called a **period**, and repeats that pattern over identical periods. The completion of one full pattern is called a **cycle**.

A **nonperiodic signal** changes without exhibiting a pattern or cycle that repeats over time. Both analog and digital signals can be periodic or nonperiodic.

In data communications, we commonly use *periodic analog signals* (because they need less bandwidth) and *nonperiodic digital signals* (because they can represent variation in data).

## 4.3 Periodic analog signals

Periodic analog signals can be classified as simple or composite.

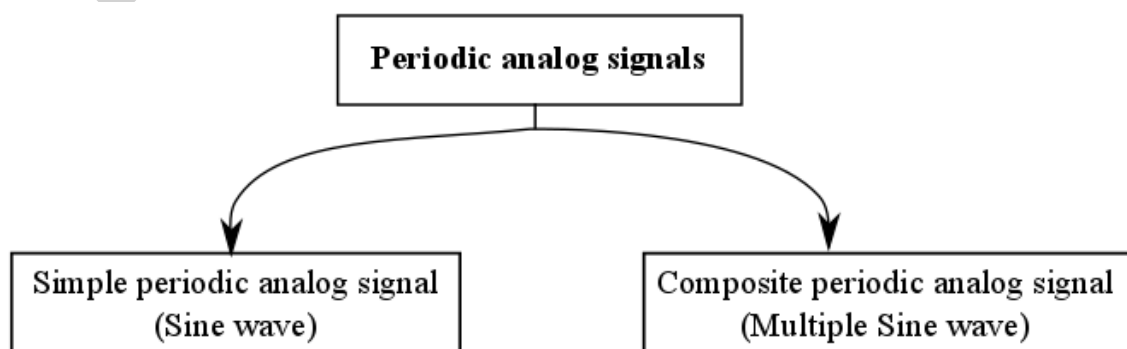

Figure 4.2 Classification of periodic analog signals

### 4.3.1 Sine Wave

Figure 4.3 shows a sine wave. Each cycle consists of a single arc above the time axis followed by a single arc below it. A sine wave can be represented by **three parameters**: the 1) *peak amplitude*, 2) the *frequency*, and 3) the *phase*.

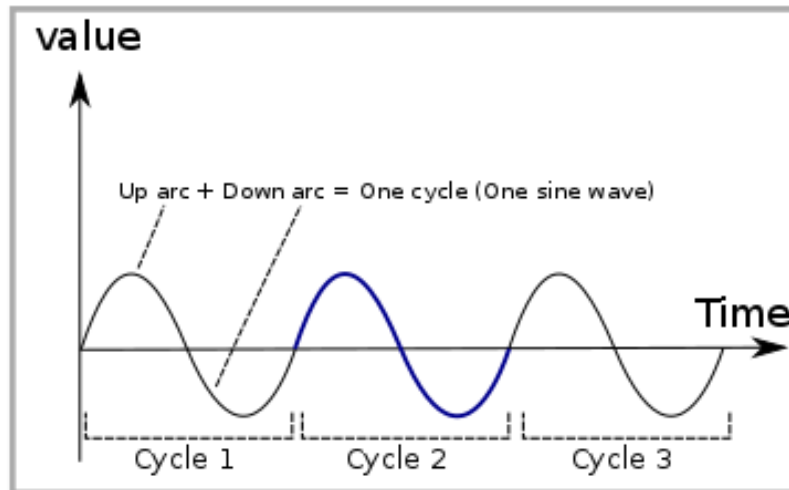

Figure 4.3 Sine wave

#### 1) Peak amplitude

The peak amplitude of a signal is the absolute **value** of its highest intensity (the energy). Figure 4.4 shows two signals and their peak amplitudes. For electric signals, peak amplitude is normally measured in *volts*. The power in your house can be represented by a sine wave with a peak amplitude of 220 to 240 V, whereas the peak value of an AA battery is normally 1.5 V.

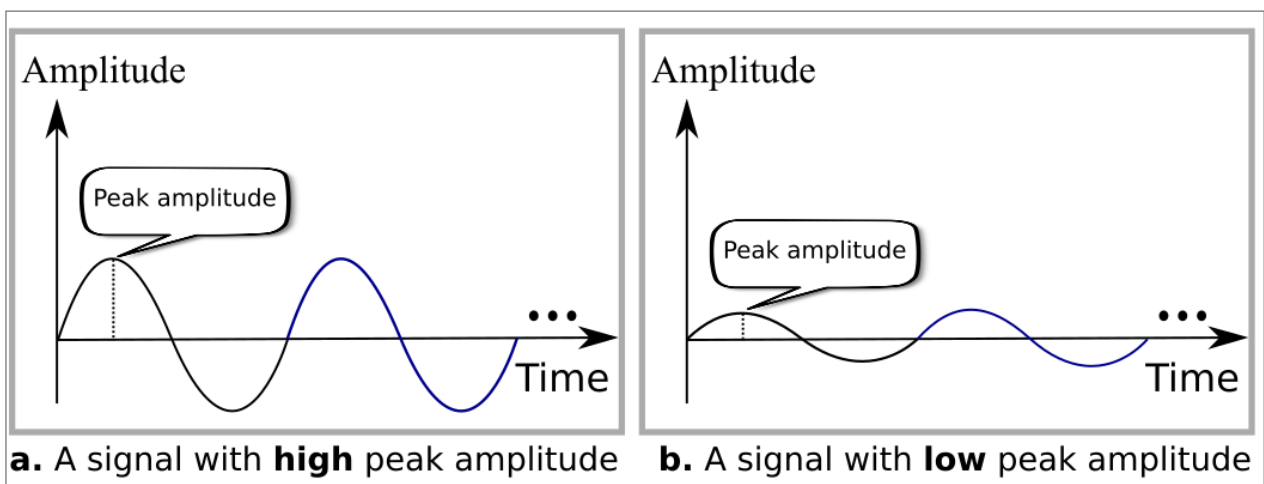

Figure 4.4 Two signals with the same phase and frequency, but different amplitudes

## 2) Period and Frequency

**Period** refers to the amount of time, in seconds, a signal needs to complete 1 cycle. **Frequency** refers to the number of periods in 1 s. Formally expressed in Hertz (Hz), which is cycle per second. Note that period and frequency are just one characteristic defined in two ways. Period is the inverse of frequency, and frequency is the inverse of period, as the following formulas show.

$$f = \frac{1}{T} \quad \text{and} \quad T = \frac{1}{f} \quad (f: \text{frequency } T: \text{time})$$

Units of period and frequency are shown in Table 4.1.

**Table 4.1** Units of period and frequency

<i>Unit</i>	<i>Equivalent</i>
Seconds (s)	1 s
Milliseconds (ms)	$10^{-3}$ s
Microseconds ( $\mu$ s)	$10^{-6}$ s
Nanoseconds (ns)	$10^{-9}$ s
Picoseconds (ps)	$10^{-12}$ s

Units of period

<i>Unit</i>	<i>Equivalent</i>
Hertz (Hz)	1 Hz
Kilohertz (kHz)	$10^3$ Hz
Megahertz (MHz)	$10^6$ Hz
Gigahertz (GHz)	$10^9$ Hz

Units of frequency

Figure 4.5 shows two signals and their frequencies.

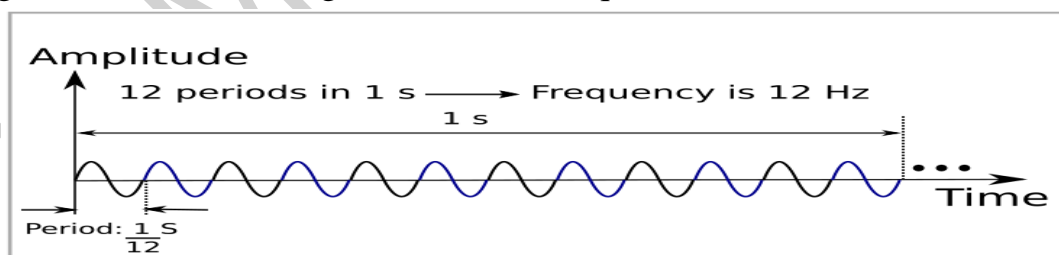

**a.** A signal with a frequency of 12 Hz

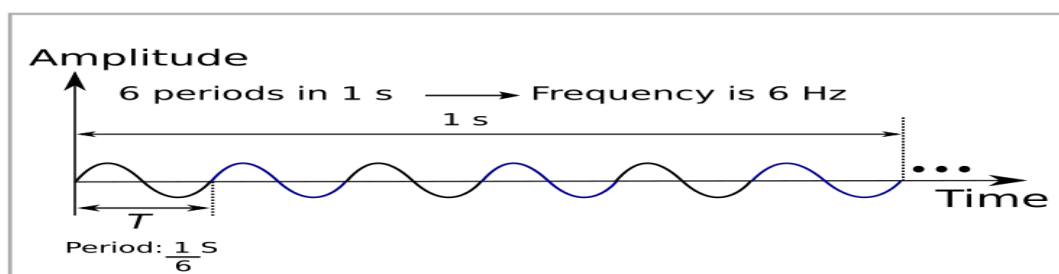

**b.** A signal with a frequency of 6 Hz

**Figure 4.5** Two signals with the same amplitude and phase, but different frequencies

### Example 1

The power we use at home has a frequency of 60 Hz. The period of this sine wave can be determined as follows:

$$T = \frac{1}{f} = \frac{1}{60} = 0.0166 \text{ s} = 0.0166 \times 10^3 \text{ ms} = 16.6 \text{ ms}$$

### Example 2

Express a period of 100 ms in microseconds.

#### Solution

$$100 \text{ ms} = 100 \times 10^{-3} \times 10^6 \mu\text{s} = 10^2 \times 10^{-3} \times 10^6 \mu\text{s} = 10^5 \mu\text{s}$$

(milliseconds) (second) وحدة الملي ثانية من وحدة الوقت من وحدة الملي ثانية (second) الى وحدة الثانية (second) الى وحدة المايكرو ثانية (Microseconds) عند الضرب تُجمع الأسس

### Example 3

The period of a signal is 100 ms. What is its frequency in kilohertz?

#### Solution

First we change 100 ms to seconds, and then we calculate the frequency from the period (1 Hz =  $10^{-3}$  kHz).

$$100 \text{ ms} = 100 \times 10^{-3} \text{ s} = 10^{-1} \text{ s}$$

$$f = \frac{1}{T} = \frac{1}{10^{-1}} \text{ Hz} = 10 \text{ Hz} = 10 \times 10^{-3} \text{ kHz} = 10^{-2} \text{ kHz}$$

## 3) Phase

The term phase describes the position of the waveform relative to time 0. It indicates the status of the first cycle (how much the wave is shifted from 0 on the time axis).



## 4) Wavelength

Wavelength is another characteristic of a signal traveling through a transmission medium. Wavelength binds the period or the frequency of a simple sine wave to the **propagation speed** of the medium (see Figure 4.6).

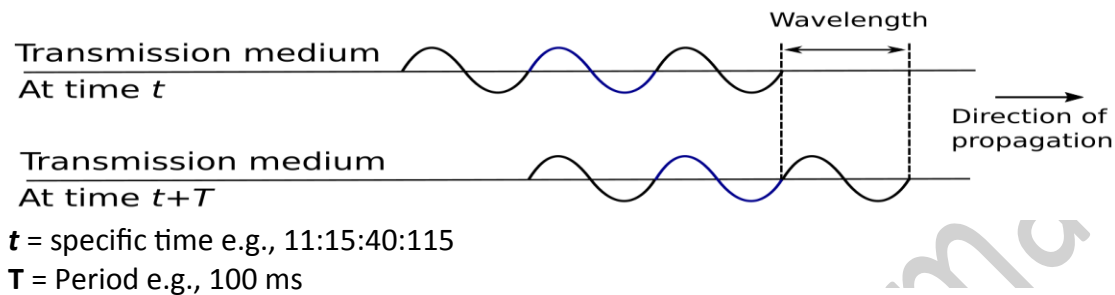

**Figure 4.6** Wavelength and period

The wavelength is normally measured in micrometres (microns) instead of meters. For example, the wavelength of **red light in air** is  $0.75 \mu\text{s}$ . But In a **Coaxial** or **fibre-optic** cable the wavelength is shorter ( $0.5 \mu\text{s}$ ) *because* the propagation speed in the cable is decreased.

### 4.3.2 Composite Signals

The previous section focused on simple sine waves which have many applications in daily life. We can send a single sine wave to carry electric energy from one place to another. For example, the power company sends a single sine wave with a frequency of 50 Hz to distribute electric energy to houses and businesses.

If we had only one single sine wave to convey a conversation over the phone, it would make no sense and carry no information. We would just hear a buzz. **Therefore**, we need to send a composite signal to communicate data; a single-frequency sine wave is not useful in data communications.

The **composite signal** is a combination of simple sine waves with different frequencies, amplitudes, and phases.

A composite signal can be periodic or nonperiodic as shown in the following:

- A **periodic composite signal** can be decomposed into a series of simple sine waves with *discrete frequencies* (the frequencies that have integer values: 1, 2, 3, and so on).
- A **nonperiodic composite signal** can be decomposed into a combination of an infinite number of simple sine waves with continuous frequencies (the frequencies that have real values: 0.1, 0.2, 0.3, and so on).

### 4.3.3 Bandwidth

**Bandwidth** is the range of frequencies contained in a composite signal. The bandwidth is normally a difference between two numbers. For example, if a composite signal contains frequencies between 1000 and 5000, its bandwidth is  $5000 - 1000$ , or 4000.

Figure 4.7 shows the concept of bandwidth. The bandwidth of the periodic signal contains all integer frequencies between 1000 and 5000 (1000, 1001, 1002, ...). The bandwidth of the nonperiodic signals has the same range, but the frequencies are **continuous**.

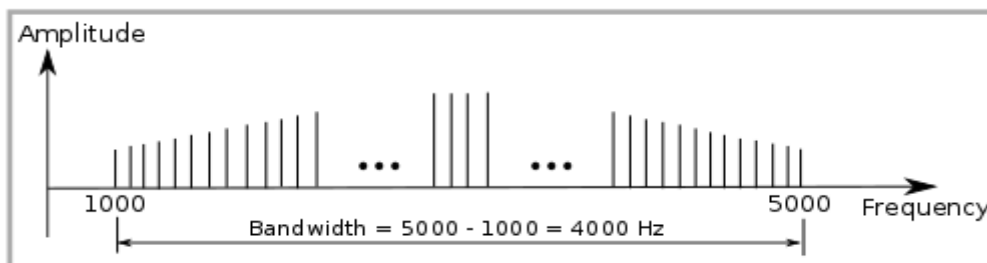

a. Bandwidth of a periodic signal

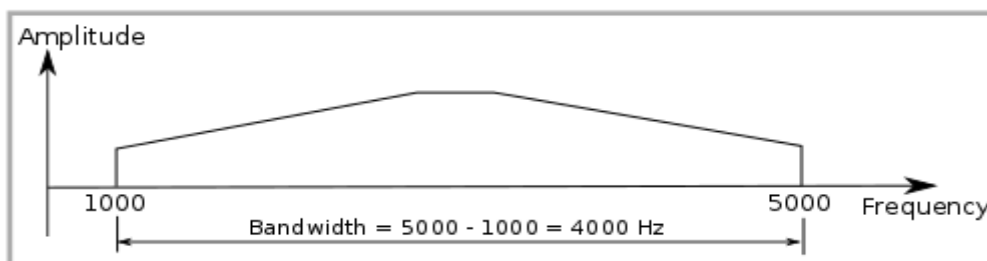

b. Bandwidth of a nonperiodic signal

**Figure 4.7** The bandwidth of periodic and nonperiodic composite signals

### Example 4

If a periodic signal is decomposed into five sine waves with frequencies of 100, 300, 500, 700, and 900 Hz, what is its bandwidth? Draw the spectrum, assuming all components have a **maximum amplitude of 10 V**.

### Solution

Let  $f_h$  be the highest frequency,  $f_l$  the lowest frequency, and  $B$  the bandwidth.

Then: 
$$B = f_h - f_l = 900 - 100 = 800 \text{ Hz}$$

The spectrum has only five spikes, at 100, 300, 500, 700, and 900 Hz (see Figure 4.8).

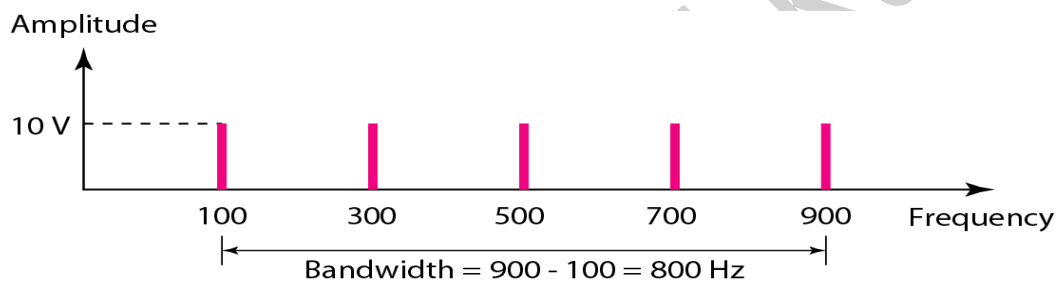

**Figure 4.8** The bandwidth for Example 4

### Example 5

A periodic signal has a bandwidth of 20 Hz. The highest frequency is 60 Hz. What is the lowest frequency? Draw the spectrum if the signal contains all frequencies of the **same amplitude**.

### Solution

Let  $f_h$  be the highest frequency,  $f_l$  the lowest frequency, and  $B$  the bandwidth.

Then: 
$$B = f_h - f_l \rightarrow 20 = 60 - f_l \rightarrow f_l = 60 - 20 = 40 \text{ Hz}$$

The spectrum contains all integer frequencies. We show this by a series of spikes (see Figure 4.9).

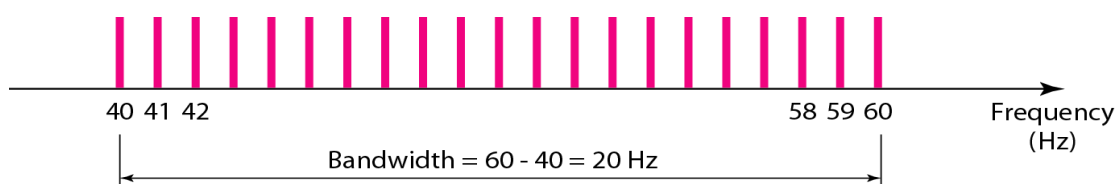

**Figure 4.9** The bandwidth for Example 5



Baghdad University  
Collage of Ibn-Al-Haitham for Pure  
Science  
Department of Computer Science



جامعة بغداد  
كلية التربية للعلوم الصرفة / ابن الهيثم  
قسم علوم الحاسبات

المرحلة الرابعة

صباحي + مسائي

(شبكات واتصالات - محاضرات النظري)

ملزمة رقم 5

## Data communication and Networks

### Chapter 5: Digital Signals, Transmission Impairment, Network Performance & Transmission Media

Dr. Mohammed Kamal Nsaif

Dr. Wisal Hashim Abdulsalam

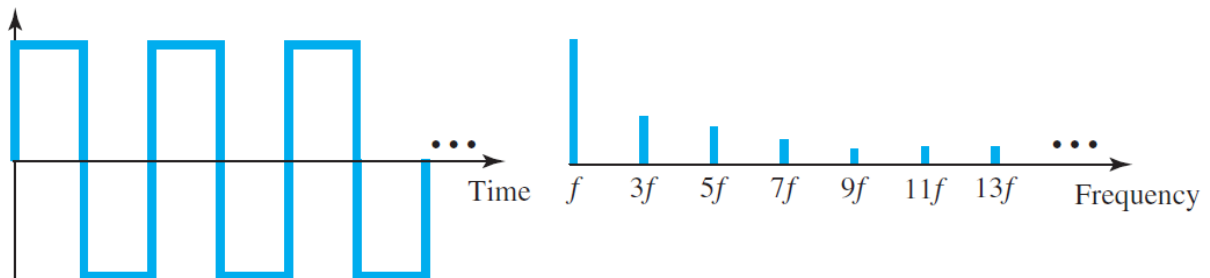

## 5. Digital Signals

In addition to being represented by an analog signal, information can also be represented by a digital signal. For example, a 1 can be encoded as a positive voltage and a 0 as zero voltage. A digital signal can have more than two levels. In this case, we can send more than 1 bit for each level. Figure 5.1 shows two signals, one with two levels and the other with four. We send 1 bit per level in part a of the figure and 2 bits per level in part b of the figure.

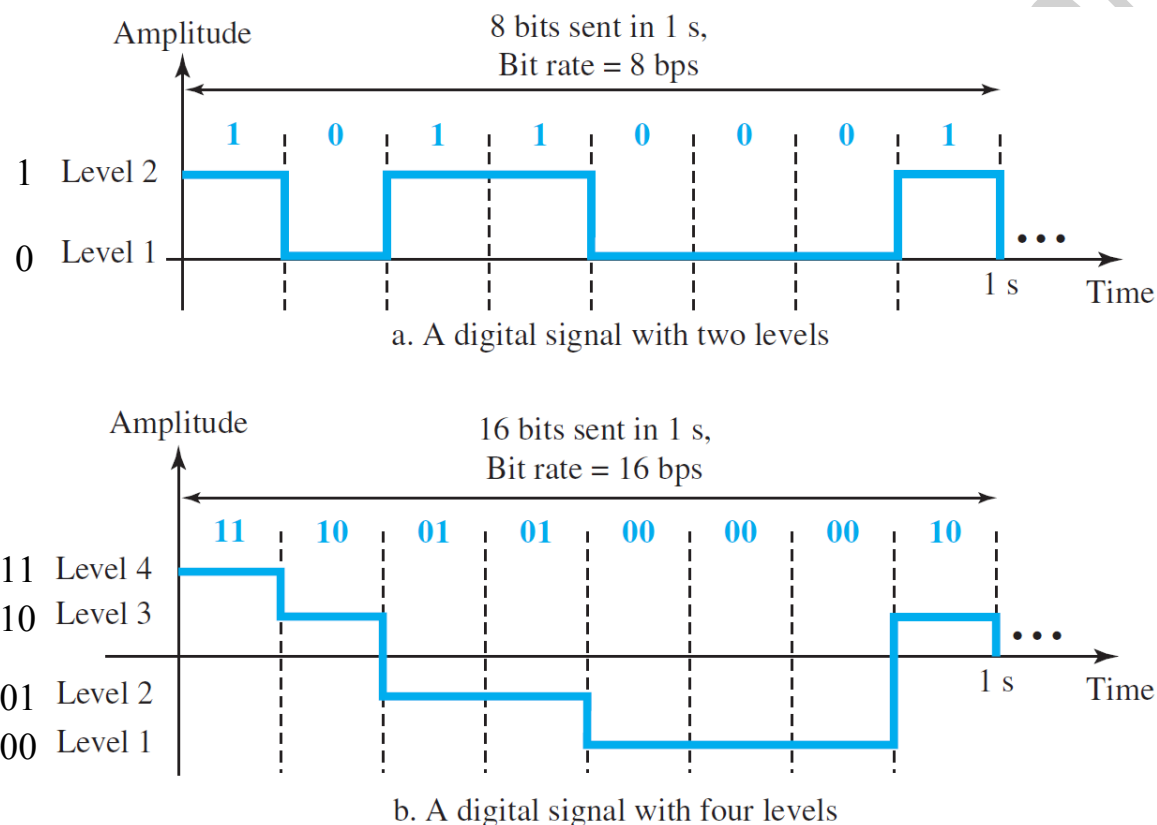

**Figure 5.1** Two digital signals: one with two signal levels and the other with four signal levels

### 5.1 Bit Rate

Most digital signals are nonperiodic, and thus period and frequency are not appropriate characteristics. Another term—**bit rate** (instead of *frequency*)—is used to describe digital signals. The **bit rate** is the number of bits sent in 1s, expressed in bits per second (bps). Figure 5.1 shows the bit rate for two signals.

### Example 5.1

Assume we need to download text documents at the rate of 100 pages per second. What is the required bit rate of the channel?

#### Solution

A page is an average of 24 lines with 80 characters in each line. If we assume that one character requires 8 bits, the bit rate is

$$//////// 100 \times 24 \times 80 \times 8 = 1,536,000 \text{ bps} = 1.536 \text{ Mbps} //////////$$

### Example 5.2

A digitized voice channel is made by digitizing a 4-kHz bandwidth analog voice signal. We need to sample the signal at twice the highest frequency (two samples per hertz). We assume that each sample requires 8 bits. What is the required bit rate?

#### Solution

The bit rate can be calculated as

$$//////// 2 \times 4000 \times 8 = 64,000 \text{ bps} = 64 \text{ kbps} //////////$$

## 5.2 Digital Signal as a Composite Analog Signal

Based on Fourier analysis, a **digital signal** is a *composite analog signal* with an infinite bandwidth. A digital signal, in the time domain, comprises connected vertical and horizontal line segments as shown in Figure 5.2.

- A vertical line in the time domain means a frequency of infinity (sudden change in time);
- A horizontal line in the time domain means a frequency of zero (no change in time)

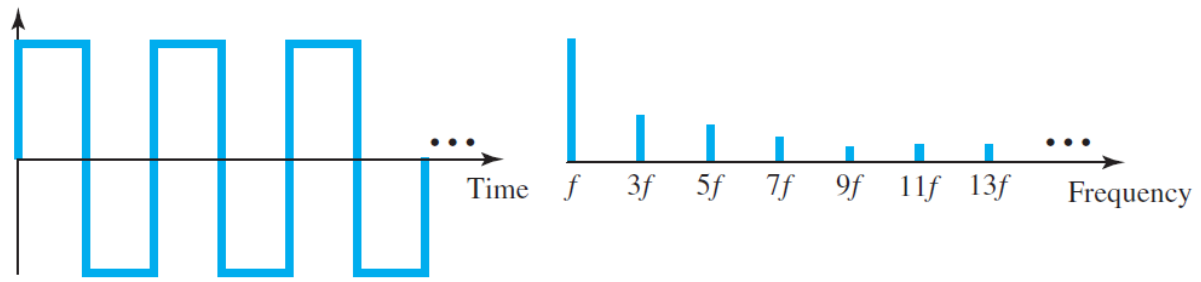

a. Time and frequency domains of periodic digital signal

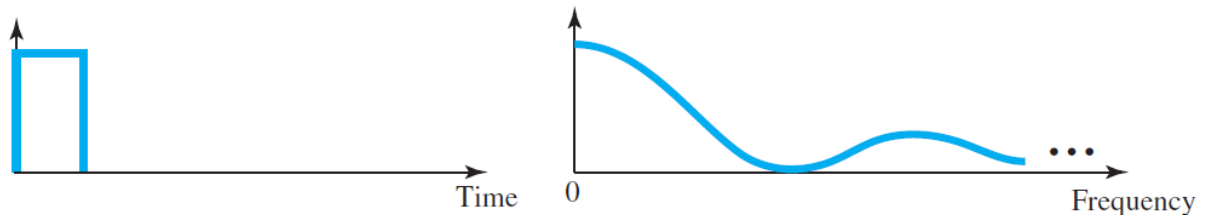

b. Time and frequency domains of nonperiodic digital signal

**Figure 5.2** The time and frequency domains of periodic and nonperiodic digital signals

Fourier analysis can be used to decompose a digital signal as shown in the following chart:

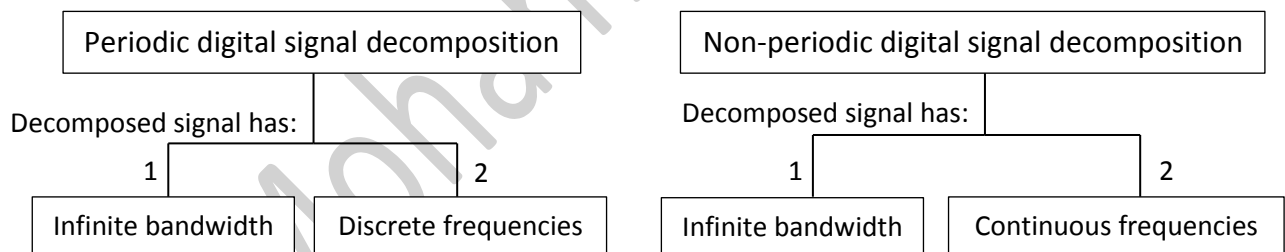

Note that both bandwidths are infinite, **but** the periodic signal has **discrete frequencies** while the nonperiodic signal has **continuous frequencies**.

### 5.3 Transmission of Digital Signals

We can transmit a digital signal from point *A* to point *B* by using one of two different approaches: *baseband transmission* or *broadband transmission* (using modulation).

For the remainder of this lecture, let us consider the case of a nonperiodic digital signal because it is used often in data communications.

### 5.3.1 Baseband Transmission

**Baseband transmission** means sending a digital signal over a channel without changing the digital signal to an analog signal. Figure 5.3 shows baseband transmission.

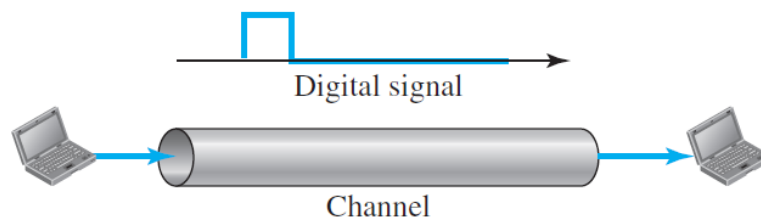
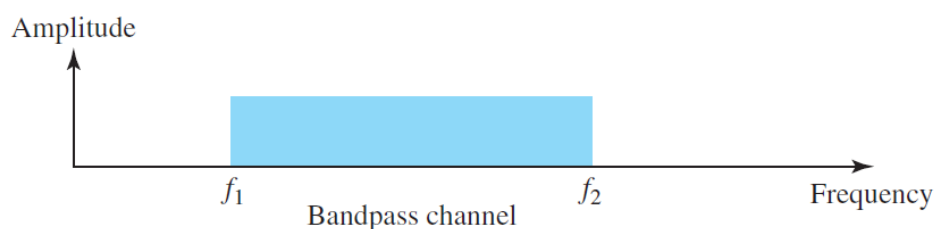

**Figure 5.3** Baseband transmission

Baseband transmission requires a **low-pass channel**, a channel with a bandwidth that starts from zero. This is the case if we have a **dedicated medium** with a bandwidth constituting only one channel. **For example**, the entire bandwidth of a cable connecting two computers is one single channel. **As another example**, we may connect several computers to a bus, but not allow more than two stations to communicate at a time.

### 5.3.2 Broadband Transmission (Using Modulation)

**Broadband transmission** or **modulation** means changing the digital signal to an analog signal for transmission. Modulation allows us to use a **bandpass channel**—a channel with a bandwidth that does not start from zero. This type of channel is **more available** than a low-pass channel. Figure 5.4 shows a bandpass channel.

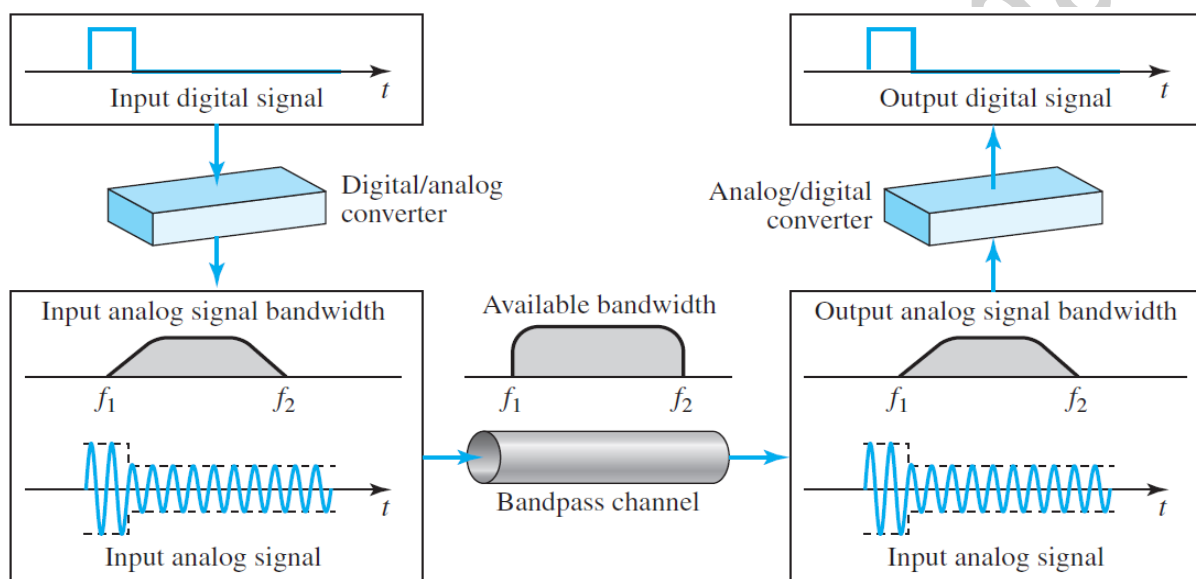

**Figure 5.4** Bandwidth of a bandpass channel



Figure 5.5 shows the modulation of a digital signal. In the figure, a digital signal is converted to a composite analog signal. We have used a single-frequency analog signal (called a *carrier*); the amplitude of the carrier has been changed to look like the digital signal. The result, however, is not a single-frequency signal; it is a composite signal. At the receiver, the received analog signal is converted to digital, and the result is a replica of what has been sent.

If the available channel is a bandpass channel, we cannot send the digital signal directly to the channel; we need to convert the digital signal to an analog signal before transmission.



**Figure 5.5** Modulation of a digital signal for transmission on a bandpass

#### Example 5.4

An **example** of broadband transmission using modulation is the sending of computer data through a **telephone lines**. The digital signal in the computer is converted to an analog signal, and then sending the analog signal. At the sending and receiving ends we can install two converters to change the digital signal to analog and vice versa. The converter, in this case, is called a **modem** (**modulator/demodulator**).

### Example 5.5

For better reception, the **digital cellular phones** convert the analog audio signal to digital and then convert it again to analog for transmission over a bandpass channel.

Analog audio signal → digital → analog  $\xrightarrow{\text{Transmission}}$

## 5.4 Transmission Impairment

Signals travel through transmission media, which are not perfect. The imperfection causes signal *impairment*. This means that the signal at the beginning of the medium is not the same as the signal at the end of the medium (what is sent is not what is received). The **causes** of impairment are *attenuation*, *distortion*, and *noise* (see Figure 5.6).

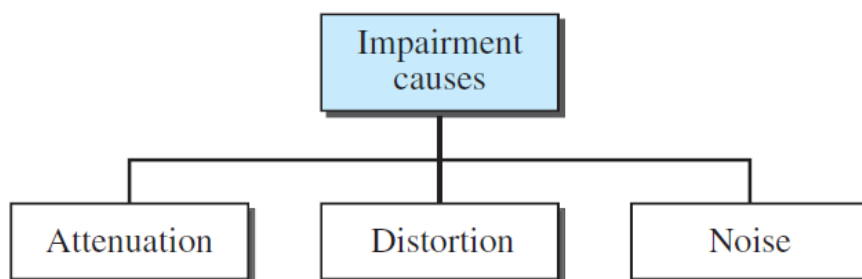

**Figure 5.6** Causes of impairment

### 5.4.1 Attenuation

**Attenuation** means a loss of energy. When a signal (simple or composite) travels through a medium, it loses some of its energy in overcoming the resistance of the medium. **That is why a wire carrying electric signals gets warm**, if not hot, after a while. Some of the electrical energy in the signal is converted to heat. To recover this loss, **amplifiers** are used to amplify the signal. Figure 5.7 shows the effect of attenuation and amplification.

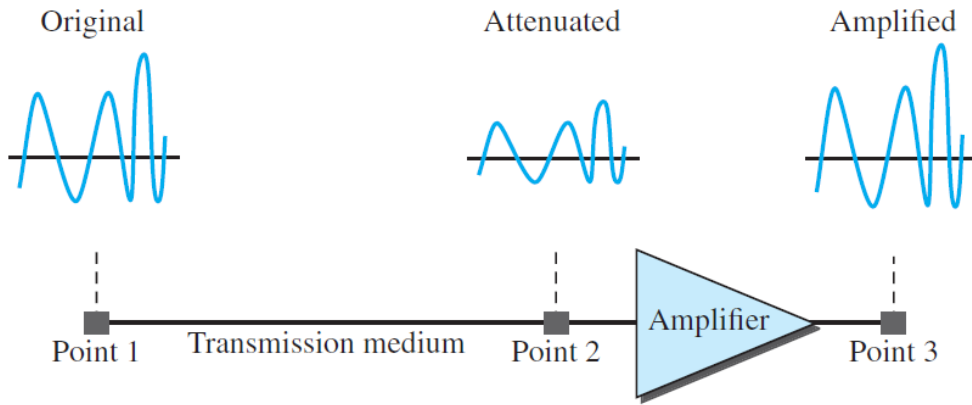

**Figure 5.7** Attenuation and amplification

## Decibel

To show that a signal has lost or gained strength, engineers use the unit of the decibel. The decibel (**dB**) measures the relative strengths of two signals or one signal at two different points. Note that the decibel is negative if a signal is attenuated and positive if a signal is amplified.

$$\text{dB} = 10 \log_{10} \frac{P_2}{P_1}$$

Variables  $P_1$  and  $P_2$  are the powers of a signal at points 1 and 2.

The  $\log_{10}$  means the logarithm to base 10, which is called the *common logarithm* or the *decimal logarithm* (\* اللوغاريتم العام او العشري).

في الرياضيات، اللوغاريتم هي العملية العكسية للدوال الأسية ويُعرّف لوغاريتم عدد ما بالنسبة لأساس ما، بأنه الأس المرفوع على الأساس والذي سينتج ذلك العدد. فعلى سبيل المثال فلوغاريتم 1000 بالنسبة للأساس 10 هو 3 لأن:

$$10^3 = 10 \times 10 \times 10 = 1000 \quad (\log_{10} 1000 = 3)$$

\* يُعرف اللوغاريتم العام او العشري بأنه لوغاريتم عدد ما بالنسبة للأساس 10 والذي يستخدم بشكل كبير في حساب التطبيقات العلمية والهندسية. في هذه المحاضرة سيتم فقط استخدام اللوغاريتم العشري.

يوجد ايضا انواع اخرى (ليست مستخدمة في هذه المحاضرة) مثلا اللوغاريتم الطبيعي والذي له تطبيقات كثيرة في الحسابات الهندسية والعلمية و في الرياضيات البحتة وخاصة في التفاضل والتكامل. في حين يعرف اللوغاريتم الثنائي لعدد ما بأنه لوغاريتمه بالنسبة للأساس 2 ويستخدم بشكل كبير في علم الحاسوب والدوال المنطقية مثلا:

The binary logarithm of 4 is 2 ( $\log_2 4 = 2$ ), and the binary logarithm of 32 is 5 ( $\log_2 32 = 5$ )

Suppose a signal travels through a transmission medium and its power is reduced to one-half. This means that  $P_2 = \frac{1}{2} P_1$ . In this case, the attenuation (loss of power) can be calculated as:

$$10 \log_{10} \frac{P_2}{P_1} = 10 \log_{10} \frac{0.5P_1}{P_1} = 10 \log_{10} 0.5 = 10(-0.3) = -3 \text{ dB}$$

### Example 5.7

A signal travels through an amplifier, and its power is increased 10 times. This means that  $P_2 = 10P_1$ . In this case, the amplification (gain of power) can be calculated as:

$$10 \log_{10} \frac{P_2}{P_1} = 10 \log_{10} \frac{10P_1}{P_1} = 10 \log_{10} 10 = 10(1) = 10 \text{ dB}$$

## 5.4.2 Distortion

**Distortion** means that the signal **changes** its form or shape. Distortion can occur in a composite signal made of different frequencies. Each signal component has its own propagation speed through a medium and, therefore, its own delay in arriving at the final destination. Differences in delay may create a difference in phase if the delay is not exactly the same as the period duration (see Figure 5.8).

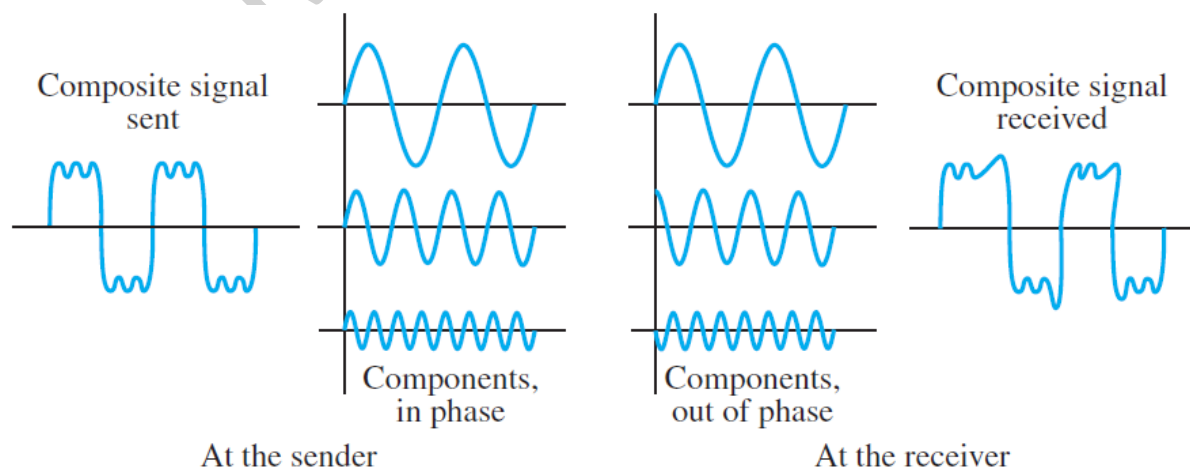

**Figure 5.8** Distortion

### 5.4.3 Noise

Noise is another cause of impairment. Several types of noise, such as *thermal noise, induced noise, crosstalk, and impulse noise*, may corrupt the signal.

- **Thermal noise** is the random motion of electrons in a wire, which creates an extra signal not originally sent by the transmitter.
- **Induced noise** comes from sources such as motors and appliances. These devices act as a sending antenna, and the transmission medium acts as the receiving antenna.
- **Crosstalk** is the effect of one wire on the other. One wire acts as a sending antenna and the other as the receiving antenna.
- **Impulse noise** is a spike (a signal with high energy in a very short time) that comes from power lines, lightning, and so on.

Figure 5.9 shows the effect of noise on a signal.

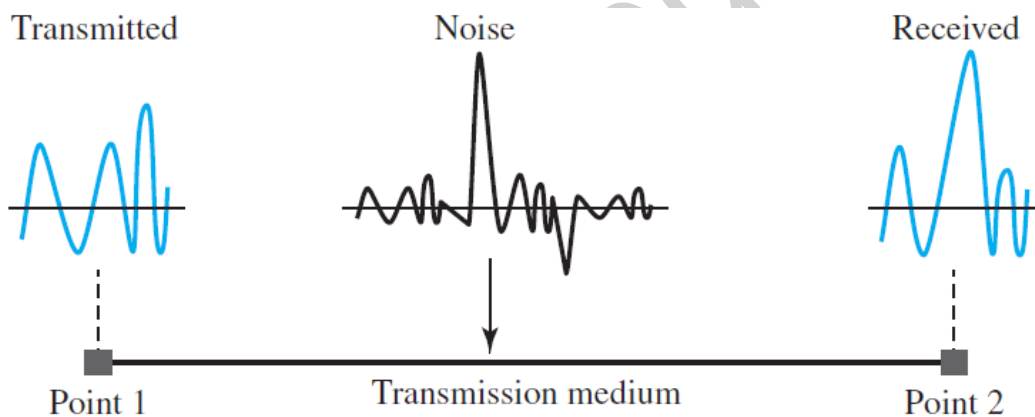

Si

**Figure 5.9** Noise

The signal-to-noise ratio is defined as:

$$\text{SNR} = \frac{\text{average signal power}}{\text{average noise power}}$$

We need to consider the average signal power and the average noise power because these may change with time. Figure 5.10 shows the idea of SNR.

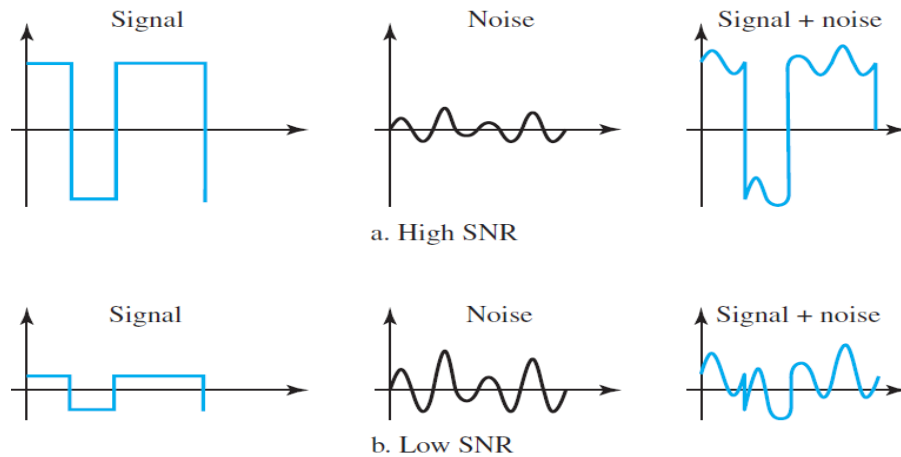

**Figure 5.10** Two cases of SNR: a high SNR and a low SNR

SNR is actually the ratio of what is wanted (signal) to what is not wanted (noise). A **high SNR means** the signal is less corrupted by noise; a **low SNR means** the signal is more corrupted by noise.

Because SNR is the ratio of two powers, it is often described in *decibel* units,  $\text{SNR}_{\text{dB}}$ , defined as

$$\text{SNR}_{\text{dB}} = 10 \log_{10} \text{SNR}$$

### Example 5.8

The power of a signal is 10 mW and the power of the noise is 1  $\mu\text{W}$ ; what are the values of SNR and  $\text{SNR}_{\text{dB}}$ ?

Solution

The values of SNR and  $\text{SNR}_{\text{dB}}$  can be calculated as follows:

$$\text{SNR} = (10,000 \mu\text{W}) / (1 \mu\text{W}) = 10,000 \quad \text{SNR}_{\text{dB}} = 10 \log_{10} 10,000 = 10 \log_{10} 10^4 = 40$$

### Example 5.9

The values of SNR and  $\text{SNR}_{\text{dB}}$  for a noiseless channel are

$$\text{SNR} = (\text{signal power}) / 0 = \infty \quad \longrightarrow \quad \text{SNR}_{\text{dB}} = 10 \log_{10} \infty = \infty$$

We can never achieve this ratio in real life; it is an ideal.

# Performance

In previous sections , we have discussed the tools of transmitting data (signals) over a network and how the data behave. In this section we discuss quality of service, an overall measurement of network performance.

## 6.1 Bandwidth

One characteristic that measures network performance is bandwidth. However, the term can be used in two different contexts with two different measuring values: 1) *bandwidth in hertz* for example, the bandwidth of a subscriber telephone line is 4 kHz and 2) *bandwidth in bits per second* for example, the bandwidth of an Ethernet network (or the links in this network) is a maximum of 100 Mbps.

### *Relationship*

There is an explicit relationship between the bandwidth in hertz and bandwidth in bits per second. Basically, an *increase in bandwidth in hertz* means an *increase in bandwidth in bits per second*. The relationship depends on whether we have *baseband transmission* or *transmission with modulation*.

In networking, we use the term bandwidth in two contexts.

- The first, bandwidth in **hertz**, refers to the range of frequencies in a composite signal or the range of frequencies that a channel can pass.
- The second, bandwidth in **bits per second**, refers to the speed of bit transmission in a channel or link.

## 6.2 Throughput

The throughput is a **measure of how fast we can actually send data through a network**. The bandwidth in bits per second and throughput are different. For example, we may have a link with a bandwidth of 1 Mbps, but the devices connected to the end of the link may handle only 200 kbps. This means that we cannot send more than 200 kbps through this link.

Imagine a highway designed to transmit 1000 cars per minute from one point to another. However, if there is problem on the road, this number may be reduced

to 100 cars per minute. The bandwidth is 1000 cars per minute; the throughput is 100 cars per minute.

### 6.3 Latency (Delay)

The latency or delay defines how long it takes for an entire message to completely arrive at the destination. We can say that latency is made of four components: **propagation time**, **transmission time**, **queuing time** and **processing delay**.

$$\text{Latency} = \text{propagation time} + \text{transmission time} + \text{queuing time} + \text{processing delay}$$

#### Propagation Time

Propagation time **measures the time required for a bit to travel from the source to the destination**. The propagation time is calculated by dividing the distance by the propagation speed.

$$\text{Propagation time} = \text{Distance} / (\text{Propagation Speed})$$

The propagation speed of electromagnetic signals depends on **the medium and on the frequency of the signal**. For example, in a vacuum, light is propagated with a speed of  $3 \times 10^8$  m/s. It is lower in air; it is much lower in cable.

#### Example 6.1

What is the propagation time if the distance between the two points is 12,000 km? Assume the propagation speed to be  $2.4 \times 10^8$  m/s in cable.

#### Solution

We can calculate the propagation time as

$$\begin{aligned} \text{Propagation time} &= (12,000 \times 1000) / (2.4 \times 10^8) \\ &= 0.05 \text{ s} \times 10^3 = 50 \text{ ms} \end{aligned}$$

The example shows that a bit can go in only 50 ms: if there is a direct cable between the source and the destination.



## Transmission Time

In data communications we don't send just 1 bit, we send a message. The transmission time is a time between the first bit leaving the sender and the last bit arriving at the receiver, and it depends on the size of the message and the bandwidth of the channel.

$$\text{Transmission time} = \text{Message size} / \text{Bandwidth}$$

### Example 6.2

What are the propagation time and the transmission time for a 2.5-KB (kilobyte) message (an email) if the bandwidth of the network is 1 Gbps? Assume that the distance between the sender and the receiver is 12,000 km and that light travels at  $2.4 \times 10^8$  m/s.

#### Solution

We can calculate the propagation and transmission time as

$$\text{Propagation time} = (12,000 \times 1000) / (2.4 \times 10^8) = 50 \text{ ms} \quad (\text{dominant factor})$$

$$\text{Transmission time} = (2500 \times 8) / 10^9 = 0.00002 \text{ s} = 0.02 \text{ ms}$$

**Note that** in this case, because the message is short and the bandwidth is high, the **dominant factor** is the *propagation time*, not the *transmission time*. The transmission time can be ignored.

### Example 6.3

What are the propagation time and the transmission time for a 5-MB (megabyte) message (an image) if the bandwidth of the network is 1 Mbps? Assume that the distance between the sender and the receiver is 12,000 km and that light travels at  $2.4 \times 10^8$  m/s.

#### Solution

We can calculate the propagation and transmission times as

$$\text{Propagation time} = (12,000 \times 1000) / (2.4 \times 10^8) = 50 \text{ ms}$$

$$\text{Transmission time} = (5,000,000 \times 8) / 10^6 = 40 \text{ s} \quad (\text{dominant factor})$$

**Note that** in this case, because the message is very long and the bandwidth is not very high, the **dominant factor** is the *transmission time*, not the *propagation time*. The propagation time can be ignored.

## 6.4 Jitter

Another performance issue that is related to delay is jitter. We can say that the jitter problem is happened because:

- 1) different packets of data encounter different delays, and
- 2) the application using the data at the receiver site is time-sensitive (audio and video data, for example).

*For example*, if the delay for the first packet is 20 ms, for the second is 45 ms, and for the third is 40 ms, then the real-time application that uses the packets will make jitter.

## 6.5 Transmission Media

Transmission media are actually located below the physical layer and are directly controlled by the physical layer. Figure 6.1 shows the position of transmission media in relation to the physical layer.

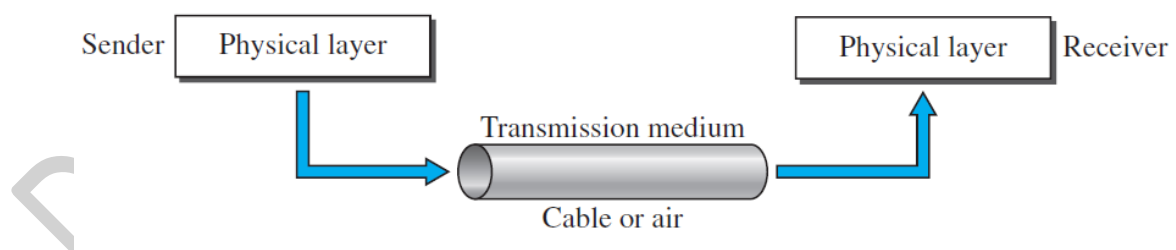

**Figure 6.1** Transmission medium and physical layer

A **transmission medium** can be defined as anything that can carry information from a source to a destination. In data communications the transmission medium is usually free space, metallic cable, or fibre-optic cable. The information is usually a signal that is the result of a conversion of data from another form.

In telecommunications, transmission media can be divided into two broad categories: **guided and unguided**. Guided media include twisted-pair cable, coaxial cable, and fibre-optic cable. Unguided medium is free space. Figure 6.2 shows this taxonomy.

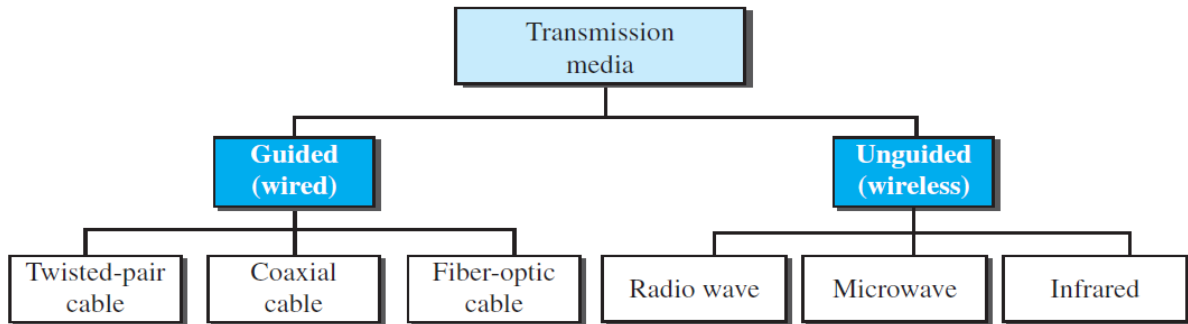

**Figure 6.2** Classes of transmission media

## 6.5.1 Twisted-Pair Cable

A twisted pair consists of two conductors (normally copper), each with its own plastic insulation, twisted together, as shown in Figure 6.3.

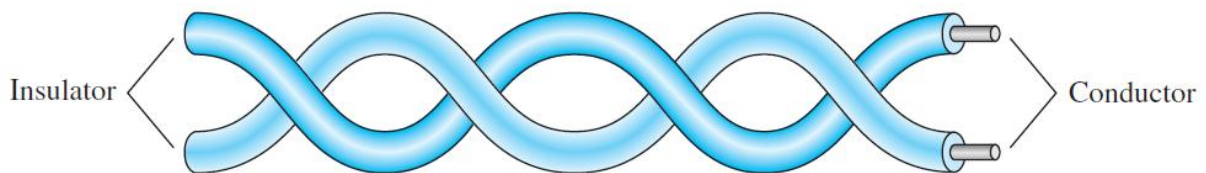

**Figure 6.3** Twisted-pair cable

One of the wires is used to carry signals to the receiver, and the other is used only as a ground reference. The receiver uses the difference between the two. In addition to the signal sent by the sender on one of the wires, interference (noise) and crosstalk may affect both wires and create unwanted signals.

**Twisting** makes it probable that both wires are *equally affected* by external influences (noise or crosstalk). The *number of twists* per unit of length (e.g., inch) has some effect on the *quality of the cable* (more twists → more quality).

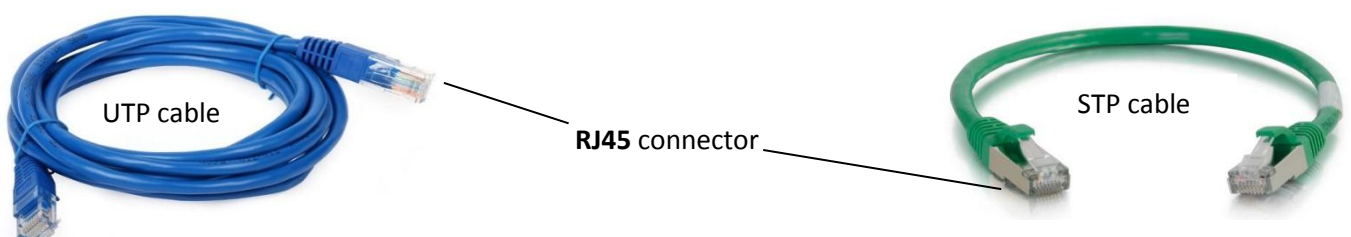

### 6.5.1.1 Unshielded Versus Shielded Twisted-Pair Cable

The most common twisted-pair cable used in communications is referred to as **unshielded twisted-pair (UTP)**. IBM has also produced a version of twisted-pair cable for its use, called **shielded twisted-pair (STP)**.

STP cable has a *metal foil or braided mesh covering* that encases each pair of insulated conductors. Figure 6.4 shows the difference between UTP and STP.

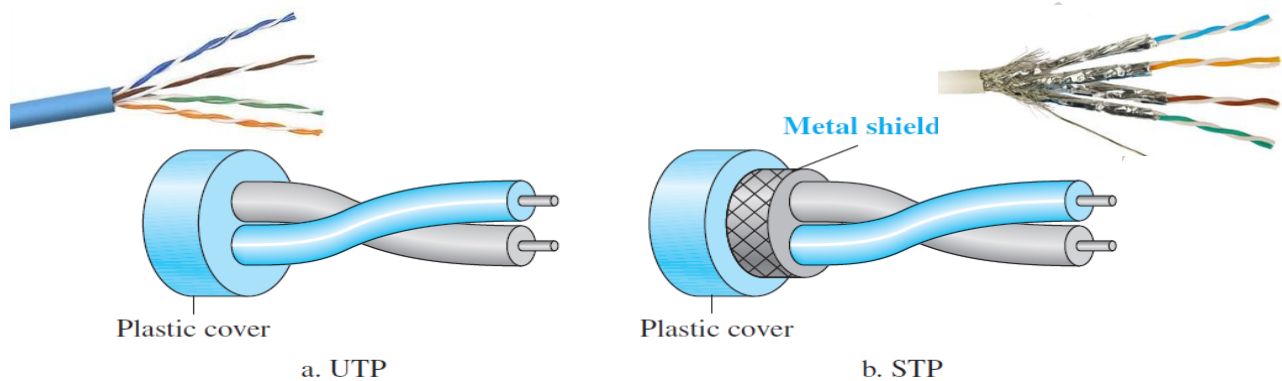

**Figure 6.4** UTP and STP cables

### 6.5.1.2 Categories

Twisted-pair cables are classified into seven categories. These categories are determined by cable quality, for example:

1. **Category 1** (Cat 1) Unshielded twisted-pair used in telephone.
2. **Category 5** (Cat 5) Unshielded twisted-pair used in LANs with 100 Mbps data rate.
3. **Category 6** (Cat 6) A new category that must be tested at a 200-Mbps data rate.
4. **Category 7** Sometimes called **SSTP** (shielded screen twisted-pair). Each pair is individually wrapped in a metallic foil. The data rate is 600 Mbps.



## 6.5.2 Coaxial Cable

Coaxial cable (or coax) carries signals of higher frequency ranges than those in twisted pair cable. Instead of having two wires, coax has an **inner core conductor** of solid wire (usually copper) and **outer conductor** serves both as a shield against noise and as the second conductor to complete the circuit (see Figure 6.5).

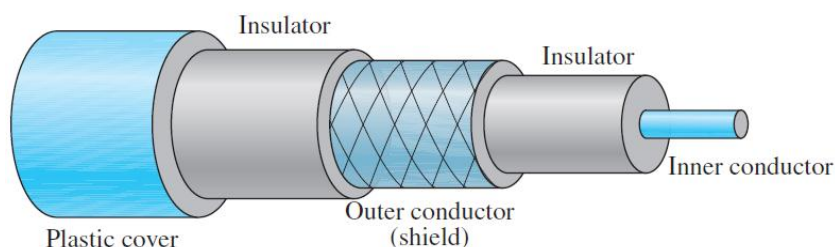

Figure 6.5 Coaxial cable

### 6.5.2.1 Coaxial Cable Standards (للاطلاع فقط)

Coaxial cables are categorized by their Radio Government (**RG**) ratings. Each RG number denotes a unique set of physical specifications, such as the wire gauge of the inner conductor, the thickness and type of the inner insulator. Each cable defined by an RG rating is adapted for a specialized function, as shown in the following table.

Categories of coaxial cables (للاطلاع فقط)

Category	Impedance	Use
RG-59	75 $\Omega$	Cable TV
RG-58	50 $\Omega$	Thin Ethernet
RG-11	50 $\Omega$	Thick Ethernet



RG-59 cable and connectors



RG-58 cable and connectors



RG-11 cable and connectors

### 6.5.2.2 Coaxial cable applications

Coaxial cables are mainly used in the following:

1. **Telephone networks.** Coaxial cable was widely used in telephone networks. However, coaxial cable has largely been replaced today with fiber-optic cable.
2. **Cable TV networks.** Coaxial cable was widely used in the traditional cable TV network. Later, however, cable TV providers replaced most of the media with fiber-optic cable.
3. **Ethernet LANs.** The **10Base-2** uses RG-58 coaxial cable with BNC connectors to transmit data at 10 Mbps with a range of 185 m. The **10Base5** uses RG-11 (thick coaxial cable) to transmit 10 Mbps with a range of 500 m.

### 6.5.3 Fiber-Optic Cable

A **fiber-optic cable** is made of glass (or plastic) and transmits signals in the form of light. The **difference in density** of the glass and cladding must be such that a beam of light moving through the core is **reflected off** the cladding instead of being **refracted** into it, as shown in **Figure 6.6**.

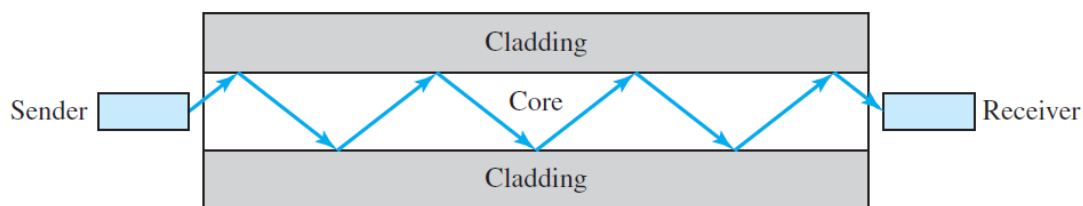

**Figure 6.6** Optical fiber

#### 6.5.3.1 Cable Composition (للاطلاع فقط)

Figure 6.7 shows the composition of a typical fiber-optic cable. The outer jacket is made of either PVC or Teflon. Inside the jacket are Kevlar strands to strengthen the cable. Kevlar is a strong material used in the fabrication of bulletproof vests. Below the Kevlar is another plastic coating to cushion the fiber. The fiber is at the center of the cable, and it consists of cladding and core. Optical fibers are defined by the ratio of the diameter of their core to the

diameter of their cladding both expressed in micrometers (for example 50/125 $\mu\text{m}$  or 100/125 $\mu\text{m}$ ).

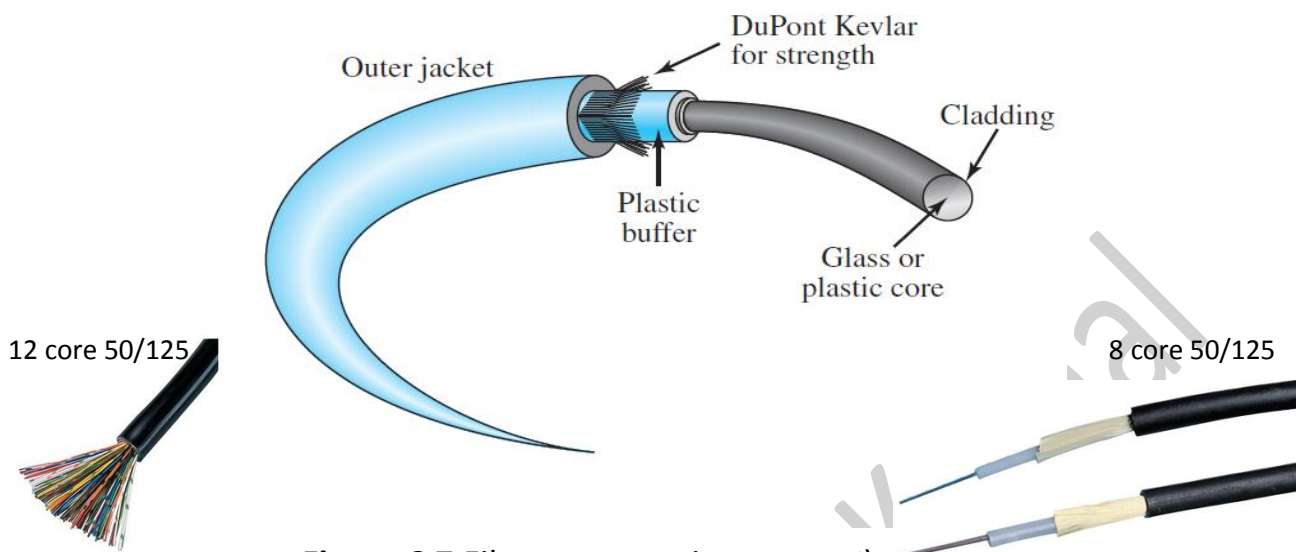

Figure 6.7 Fiber construction (للاطلاع فقط)

### 6.5.3.2 Fiberoptic applications

Fiberoptics are mainly used in the following:

1. **Backbone networks.** Fiber-optic cable is often found in **backbone networks** (central large networks) because its wide bandwidth is cost-effective (with data rate of 1600 Gbps).
2. **Cable TV networks.** Some cable TV companies use a combination of optical fiber and coaxial cable, thus creating a hybrid network.
3. **Ethernet LANs.** Local-area networks such as **100Base-FX** network (**Fast Ethernet**) and **1000Base-X** also use fiber-optic cable.

### Advantages of Optical Fiber

Fiber-optic cable has several advantages over metallic cable (twisted-pair or coaxial).

- **Higher bandwidth.** Fiber-optic cable can support higher bandwidths (and hence data rates) than coaxial or twisted pair.
- **Less signal attenuation.** A signal can run for 50 km without requiring regeneration, while need repeaters every 5 km for coaxial or twisted pair.



- **No noise.** Electromagnetic noise cannot affect fiber-optic cables.
- **Resistance to corrosiveness.** Glass is more resistant to corrosive materials than copper.
- **Light weight.** Fiber-optic cables are much lighter than copper cables.

### Disadvantages of Optical Fiber

- **Installation and maintenance.** Its installation and maintenance require expertise that is not yet available everywhere.
- **Unidirectional light propagation.** Propagation of light is unidirectional. If we need bidirectional communication, two fibers are needed.
- **Cost.** The cable and the interfaces are relatively more expensive than those of other copper media.

## UNGUIDED MEDIA: WIRELESS

**Unguided medium** transport electromagnetic waves without using a physical conductor, signals are normally broadcast through free space and thus are available to anyone.

Figure 6.8 shows the part of the electromagnetic spectrum, ranging from 3 kHz to 900 THz, used for wireless communication (Unguided medium).

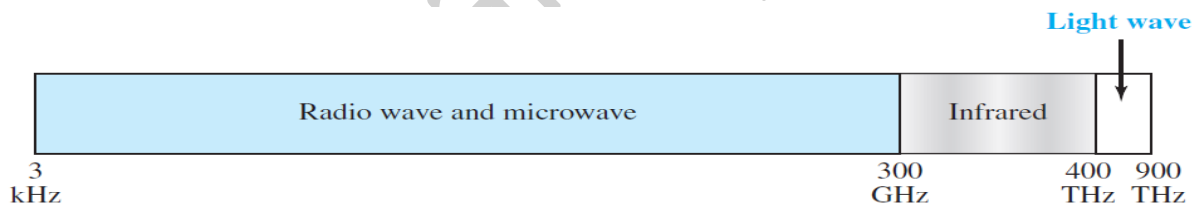

**Figure 6.8** Electromagnetic spectrum for wireless communication

Unguided signals can travel from the source to the destination in several ways: **ground propagation**, **sky propagation**, and **line-of-sight propagation**, as shown in Figure 6.9.

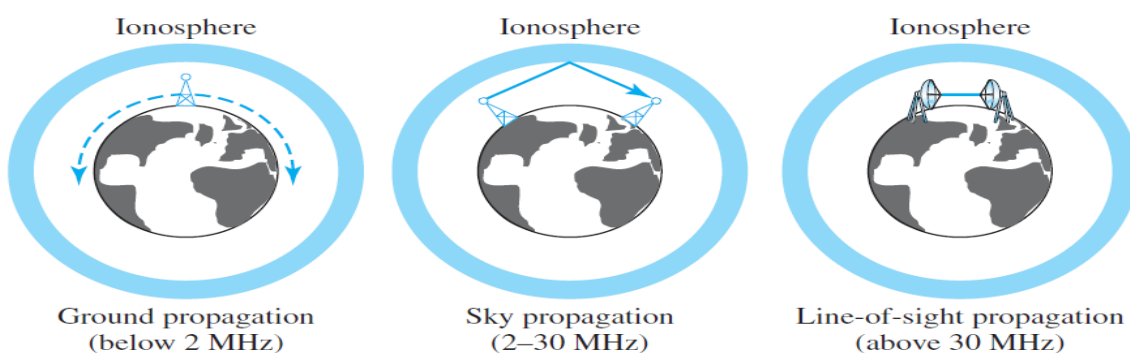

**Figure 6.9** Propagation methods



In **ground propagation**, radio waves travel through the lowest portion of the atmosphere, hugging the earth.

In **sky propagation**, higher-frequency radio waves radiate upward into the ionosphere (the layer of atmosphere) where they are reflected back to earth.

In **line-of-sight propagation**, very high-frequency signals are transmitted in straight lines directly from antenna to antenna. Antennas must be directional.

The radio waves and microwaves is divided into eight ranges, called **bands**. These bands are rated from very low frequency (VLF) to extremely high frequency (EHF) as shown in the following table.

Band	Range	Propagation	Application
very low frequency (VLF)	3–30 kHz	Ground	Long-range radio navigation
low frequency (LF)	30–300 kHz	Ground	Radio beacons and navigational locators
middle frequency (MF)	300 kHz–3 MHz	Sky	AM radio
high frequency (HF)	3–30 MHz	Sky	Citizens band (CB), ship/aircraft
very high frequency (VHF)	30–300 MHz	Sky and line-of-sight	VHF TV, FM radio
ultrahigh frequency (UHF)	300 MHz–3 GHz	Line-of-sight	UHF TV, cellular phones, paging, satellite
superhigh frequency (SHF)	3–30 GHz	Line-of-sight	Satellite
extremely high frequency (EHF)	30–300 GHz	Line-of-sight	Radar, satellite

فقط للإطلاع

### 6.5.4 Radio Waves

**Radio waves** are **omnidirectional**, when an antenna transmits radio waves; they are propagated in all directions. *This means* that the sending and receiving antennas **do not have to be aligned**, and makes them useful for multicasting in which there is one sender and many receivers. **AM radio, FM radio and television are examples of multicasting.** Figure 6.10 shows an omnidirectional antenna.

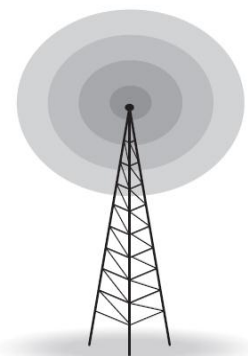
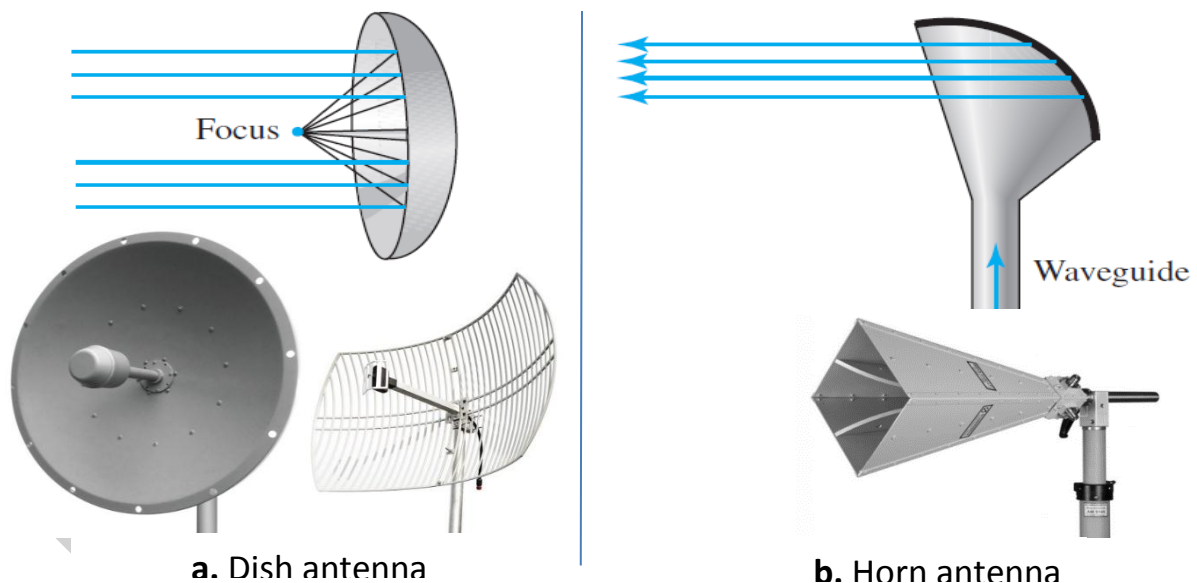

Figure 6.10 Omnidirectional

Radio waves, particularly those waves that **propagate in the sky mode**, can travel **long distances**. This makes radio waves a good candidate for **long-distance broadcasting such as AM radio**. Radio waves **can penetrate walls**.

### 6.5.5 Microwaves

Microwaves are **unidirectional**. **Microwave propagation is line-of-sight**. Since the towers with the mounted antennas need to be in direct sight of each other. Microwaves need unidirectional antennas that send out signals in one direction. Two **types of antennas** are used for microwave communications: the **dish antenna** and the **horn antenna** (see Figure 6.11). The sending and receiving antennas **need to be aligned**. Repeaters are often needed for long distance communication. Microwaves, due to their unidirectional properties, are very useful when **unicast** (one-to-one) communication is needed between the sender and the receiver. They are used in **cellular phones, satellite networks, and wireless LANs**. Very high-frequency microwaves **cannot penetrate walls**.



**Figure 6.11** Unidirectional antennas

### 6.5.6 Infrared waves

Infrared waves with frequencies from 300 GHz to 400 THz can be used for **short-range communication**.

Infrared waves, having high frequencies, **cannot penetrate walls**. This **advantageous characteristic** prevents interference between one system and another. When we use our infrared remote control, we do not interfere with the use of the remote by our neighbours. The infrared waves cannot be used outside a building **because** the sun's rays contain infrared waves that can interfere with the communication. The infrared band, almost 400 THz, has an excellent potential for data transmission. Such a wide bandwidth can be used to transmit digital data with a very high data rate.

The **Infrared Data Association** (IrDA), an association which has established standards for using these signals for communication between devices such as **keyboards, mice, PCs, and printers**. Infrared signals defined by IrDA transmit through **line of sight**; the IrDA port on the keyboard needs to point to the PC for transmission to occur.

# Performance

In previous sections , we have discussed the tools of transmitting data (signals) over a network and how the data behave. In this section we discuss quality of service, an overall measurement of network performance.

## 6.1 Bandwidth

One characteristic that measures network performance is bandwidth. However, the term can be used in two different contexts with two different measuring values: 1) *bandwidth in hertz* for example, the bandwidth of a subscriber telephone line is 4 kHz and 2) *bandwidth in bits per second* for example, the bandwidth of an Ethernet network (or the links in this network) is a maximum of 100 Mbps.

### *Relationship*

There is an explicit relationship between the bandwidth in hertz and bandwidth in bits per second. Basically, an *increase in bandwidth in hertz* means an *increase in bandwidth in bits per second*. The relationship depends on whether we have *baseband transmission* or *transmission with modulation*.

In networking, we use the term bandwidth in two contexts.

- The first, bandwidth in **hertz**, refers to the range of frequencies in a composite signal or the range of frequencies that a channel can pass.
- The second, bandwidth in **bits per second**, refers to the speed of bit transmission in a channel or link.

## 6.2 Throughput

The throughput is a **measure of how fast we can actually send data through a network**. The bandwidth in bits per second and throughput are different. For example, we may have a link with a bandwidth of 1 Mbps, but the devices connected to the end of the link may handle only 200 kbps. This means that we cannot send more than 200 kbps through this link.

Imagine a highway designed to transmit 1000 cars per minute from one point to another. However, if there is a problem on the road, this number may be reduced to 100 cars per minute. The bandwidth is 1000 cars per minute; the throughput is 100 cars per minute.

## 6.3 Latency (Delay)

The latency or delay defines how long it takes for an entire message to completely arrive at the destination. We can say that latency is made of four components: **propagation time**, **transmission time**, **queuing time** and **processing delay**.

$$\text{Latency} = \text{propagation time} + \text{transmission time} + \text{queuing time} + \text{processing delay}$$

### Propagation Time

Propagation time **measures the time required for a bit to travel from the source to the destination**. The propagation time is calculated by dividing the distance by the propagation speed.

$$\text{Propagation time} = \text{Distance} / \text{Propagation Speed}$$

The propagation speed of electromagnetic signals depends on **the medium and on the frequency of the signal**. For example, in a vacuum, light is propagated with a speed of  $3 \times 10^8$  m/s. It is lower in air; it is much lower in cable.

#### Example 6.1

What is the propagation time if the distance between the two points is 12,000 km? Assume the propagation speed to be  $2.4 \times 10^8$  m/s in cable.

#### Solution

We can calculate the propagation time as

$$\begin{aligned} \text{Propagation time} &= (12,000 \times 1000) / (2.4 \times 10^8) \\ &= 0.05 \text{ s} \times 10^3 = 50 \text{ ms} \end{aligned}$$

The example shows that a bit can go in only 50 ms: if there is a direct cable between the source and the destination.

## Transmission Time

In data communications we don't send just 1 bit, we send a message. The transmission time is a time between the first bit leaving the sender and the last bit arriving at the receiver, and it depends on the size of the message and the bandwidth of the channel.

$$\text{Transmission time} = (\text{Message size}) / \text{Bandwidth}$$

### Example 6.2

What are the propagation time and the transmission time for a 2.5-KB (kilobyte) message (an email) if the bandwidth of the network is 1 Gbps? Assume that the distance between the sender and the receiver is 12,000 km and that light travels at  $2.4 \times 10^8$  m/s.

### Solution

We can calculate the propagation and transmission time as

$$\text{Propagation time} = (12,000 \times 1000) / (2.4 \times 10^8) = 50 \text{ ms} \text{ (dominant factor)}$$

$$\text{Transmission time} = (2500 \times 8) / 10^9 = 0.00002 \text{ s} = 0.02 \text{ ms}$$

**Note that** in this case, because the message is short and the bandwidth is high, the **dominant factor** is the *propagation time*, not the *transmission time*. The transmission time can be ignored.

### Example 6.3

What are the propagation time and the transmission time for a 5-MB (megabyte) message (an image) if the bandwidth of the network is 1 Mbps? Assume that the distance between the sender and the receiver is 12,000 km and that light travels at  $2.4 \times 10^8$  m/s.

### Solution

We can calculate the propagation and transmission times as

$$\text{Propagation time} = (12,000 \times 1000) / (2.4 \times 10^8) = 50 \text{ ms}$$

$$\text{Transmission time} = (5,000,000 \times 8) / 10^6 = 40 \text{ s} \quad (\text{dominant factor})$$

**Note that** in this case, because the message is very long and the bandwidth is not very high, the **dominant factor** is the *transmission time*, not the *propagation time*. The propagation time can be ignored.

## 6.4 Jitter

Another performance issue that is related to delay is jitter. We can say that the jitter problem is happened because:

- 1) different packets of data encounter different delays, and
- 2) the application using the data at the receiver site is time-sensitive (audio and video data, for example).

*For example*, if the delay for the first packet is 20 ms, for the second is 45 ms, and for the third is 40 ms, then the real-time application that uses the packets will make jitter.

## 6.5 Transmission Media

Transmission media are actually located below the physical layer and are directly controlled by the physical layer. Figure 6.1 shows the position of transmission media in relation to the physical layer.

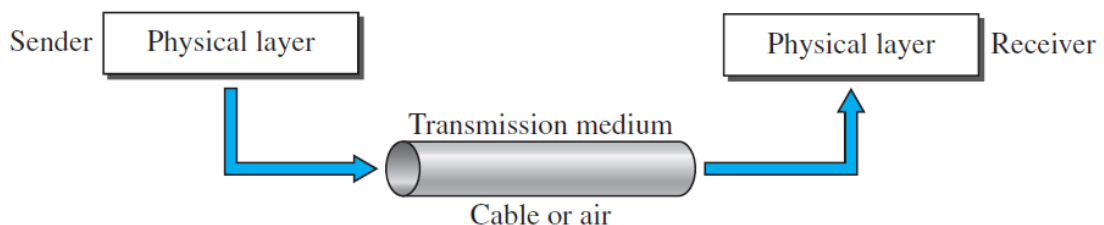

**Figure 6.1** Transmission medium and physical layer

A **transmission medium** can be defined as anything that can carry information from a source to a destination. In data communications the transmission medium is usually free space, metallic cable, or fibre-optic cable. The information is usually a signal that is the result of a conversion of data from another form.

In telecommunications, transmission media can be divided into two broad categories: **guided and unguided**. Guided media include twisted-pair cable, coaxial cable, and fibre-optic cable. Unguided medium is free space. Figure 6.2 shows this taxonomy.

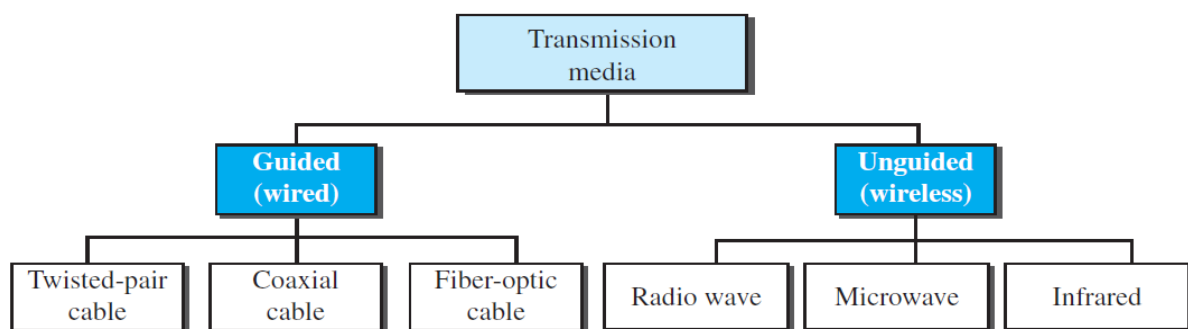

**Figure 6.2** Classes of transmission media

### 6.5.1 Twisted-Pair Cable

A twisted pair consists of two conductors (normally copper), each with its own plastic insulation, twisted together, as shown in Figure 6.3.

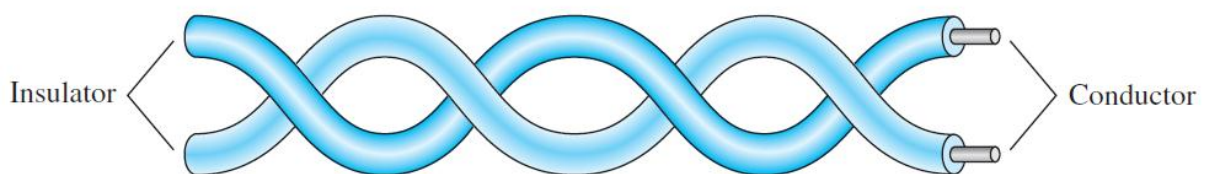
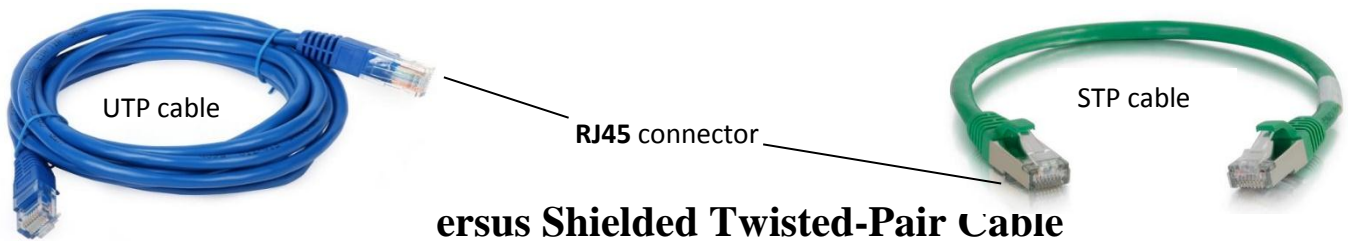

**Figure 6.3** Twisted-pair cable

One of the wires is used to carry signals to the receiver, and the other is used only as a ground reference. The receiver uses the difference between the two. In addition to the signal sent by the sender on one of the wires, interference (noise) and crosstalk may affect both wires and create unwanted signals.

**Twisting** makes it probable that both wires are *equally affected* by external influences (noise or crosstalk). The *number of twists* per unit of length (e.g., inch) has some effect on the *quality of the cable* (more twists → more quality).





### versus Shielded Twisted-Pair Cable

The most common twisted-pair cable used in communications is referred to as **unshielded twisted-pair (UTP)**. IBM has also produced a version of twisted-pair cable for its use, called **shielded twisted-pair (STP)**.

STP cable has a *metal foil or braided mesh covering* that encases each pair of insulated conductors. Figure 6.4 shows the difference between UTP and STP.

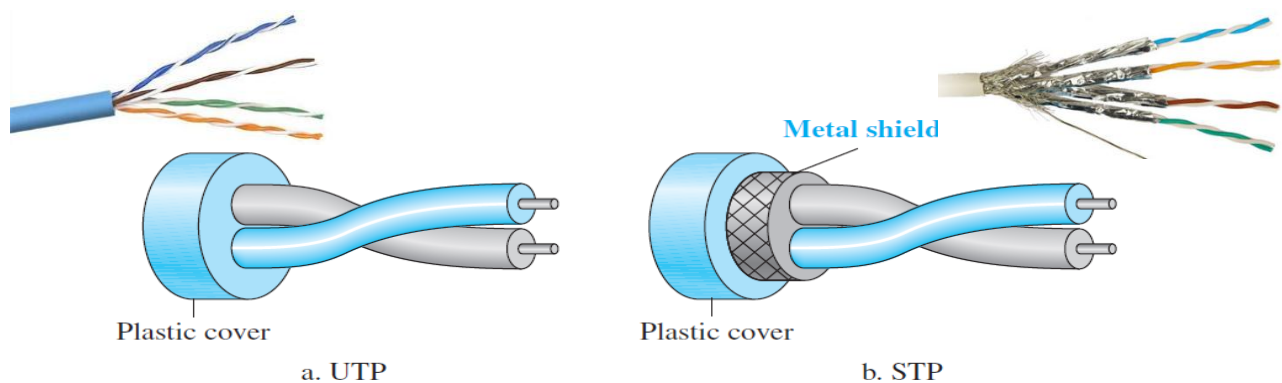
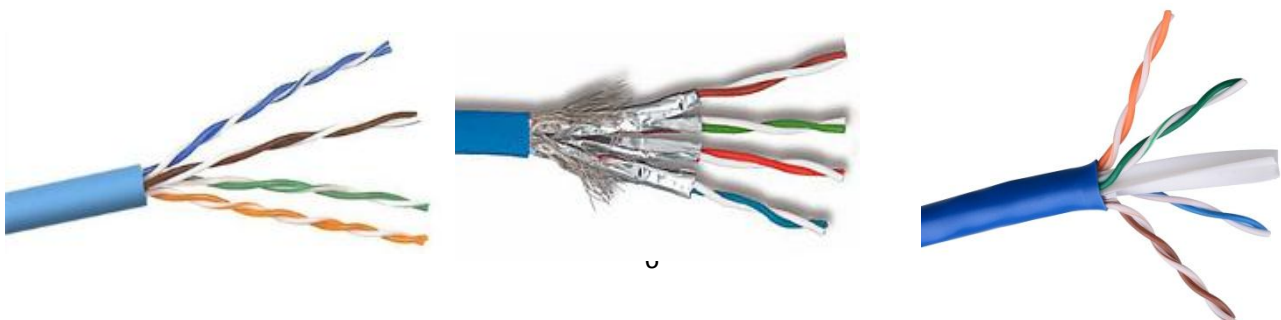

**Figure 6.4** UTP and STP cables

### 6.5.1.2 Categories

Twisted-pair cables are classified into seven categories. These categories are determined by cable quality, for example:

1. **Category 1** (Cat 1) Unshielded twisted-pair used in telephone.
2. **Category 5** (Cat 5) Unshielded twisted-pair used in LANs with 100 Mbps data rate.
3. **Category 6** (Cat 6) A new category that must be tested at a 200-Mbps data rate.
4. **Category 7** Sometimes called **SSTP** (shielded screen twisted-pair). Each pair is individually wrapped in a metallic foil. The data rate is 600 Mbps.



## 6.5.2 Coaxial Cable

Coaxial cable (or coax) carries signals of higher frequency ranges than those in twisted pair cable. Instead of having two wires, coax has an **inner core conductor** of solid wire (usually copper) and **outer conductor** serves both as a shield against noise and as the second conductor to complete the circuit (see Figure 6.5).

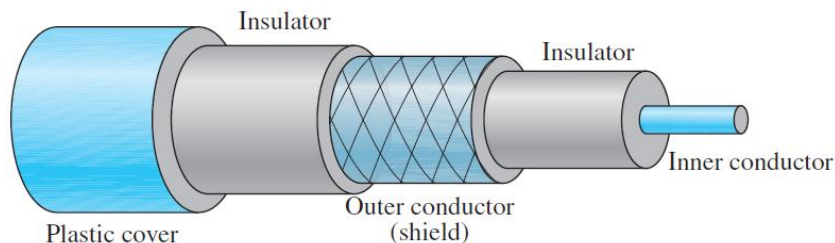

**Figure 6.5** Coaxial cable

### 6.5.2.1 Coaxial Cable Standards (للاطلاع فقط)

Coaxial cables are categorized by their Radio Government (**RG**) ratings. Each RG number denotes a unique set of physical specifications, such as the wire gauge of the inner conductor, the thickness and type of the inner insulator. Each cable defined by an RG rating is adapted for a specialized function, as shown in the following table.

Categories of coaxial cables (للاطلاع فقط)

Category	Impedance	Use
RG-59	75 $\Omega$	Cable TV
RG-58	50 $\Omega$	Thin Ethernet
RG-11	50 $\Omega$	Thick Ethernet





RG-59 cable and connectors

RG-58 cable and connectors

RG-11 cable and connectors

### 6.5.2.2 Coaxial cable applications

Coaxial cables are mainly used in the following:

1. **Telephone networks.** Coaxial cable was widely used in telephone networks. However, coaxial cable has largely been replaced today with fiber-optic cable.
2. **Cable TV networks.** Coaxial cable was widely used in the traditional cable TV network. Later, however, cable TV providers replaced most of the media with fiber-optic cable.
3. **Ethernet LANs.** The **10Base-2** uses RG-58 coaxial cable with BNC connectors to transmit data at 10 Mbps with a range of 185 m. The **10Base5** uses RG-11 (thick coaxial cable) to transmit 10 Mbps with a range of 500 m.

## 6.5.3 Fiber-Optic Cable

A **fiber-optic cable** is made of glass (or plastic) and transmits signals in the form of light. The **difference in density** of the glass and cladding must be such that a beam of light moving through the core is **reflected off** the cladding instead of being **refracted** into it, as shown in Figure 6.6.

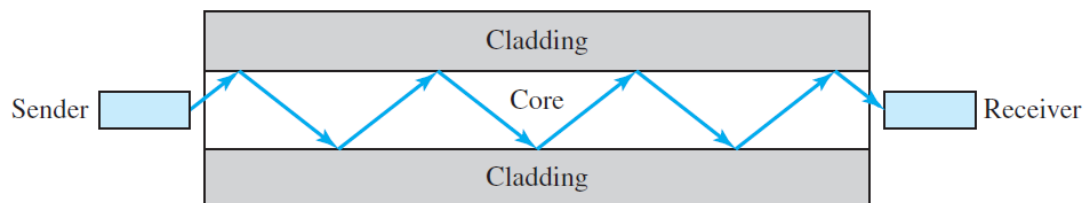
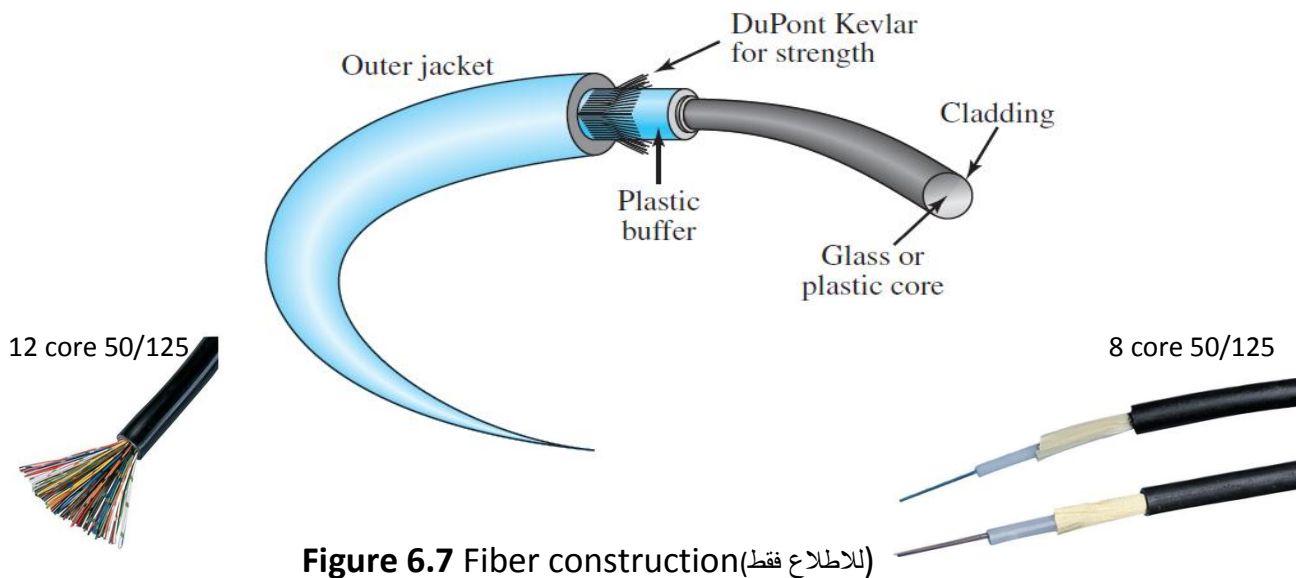

**Figure 6.6** Optical fiber

### 6.5.3.1 Cable Composition (للاطلاع فقط)

Figure 6.7 shows the composition of a typical fiber-optic cable. The outer jacket is made of either PVC or Teflon. Inside the jacket are Kevlar strands to

strengthen the cable. Kevlar is a strong material used in the fabrication of bulletproof vests. Below the Kevlar is another plastic coating to cushion the fiber. The fiber is at the center of the cable, and it consists of cladding and core. Optical fibers are defined by the ratio of the diameter of their core to the diameter of their cladding both expressed in micrometers (for example 50/125 $\mu\text{m}$  or 100/125 $\mu\text{m}$ ).



**Figure 6.7** Fiber construction (للاطلاع فقط)

### 6.5.3.2 Fiberoptic applications

Fiberoptics are mainly used in the following:

1. **Backbone networks.** Fiber-optic cable is often found in **backbone networks** (central large networks) because its wide bandwidth is cost-effective (with data rate of 1600 Gbps).
2. **Cable TV networks.** Some cable TV companies use a combination of optical fiber and coaxial cable, thus creating a hybrid network.
3. **Ethernet LANs.** Local-area networks such as **100Base-FX** network (**Fast Ethernet**) and **1000Base-X** also use fiber-optic cable.

### Advantages of Optical Fiber

Fiber-optic cable has several advantages over metallic cable (twisted-pair or coaxial).

- **Higher bandwidth.** Fiber-optic cable can support higher bandwidths (and hence data rates) than coaxial or twisted pair.
- **Less signal attenuation.** A signal can run for 50 km without requiring regeneration, while need repeaters every 5 km for coaxial or twisted pair.
- **No noise.** Electromagnetic noise cannot affect fiber-optic cables.
- **Resistance to corrosiveness.** Glass is more resistant to corrosive materials than copper.
- **Light weight.** Fiber-optic cables are much lighter than copper cables.

### Disadvantages of Optical Fiber

- **Installation and maintenance.** Its installation and maintenance require expertise that is not yet available everywhere.
- **Unidirectional light propagation.** Propagation of light is unidirectional. If we need bidirectional communication, two fibers are needed.
- **Cost.** The cable and the interfaces are relatively more expensive than those of other copper media.

## UNGUIDED MEDIA: WIRELESS

**Unguided medium** transport electromagnetic waves without using a physical conductor, signals are normally broadcast through free space and thus are available to anyone.

Figure 6.8 shows the part of the electromagnetic spectrum, ranging from 3 kHz to 900 THz, used for wireless communication (Unguided medium).

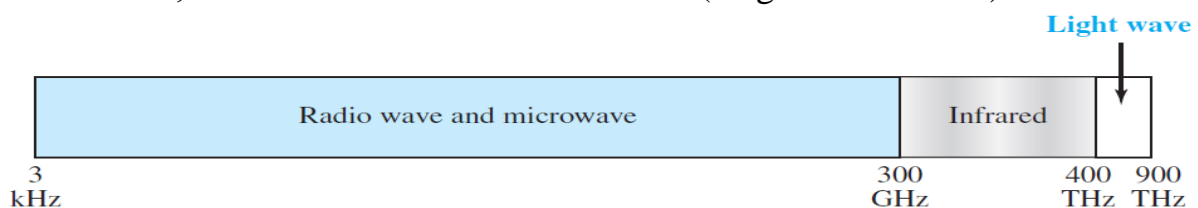

**Figure 6.8** Electromagnetic spectrum for wireless communication

Unguided signals can travel from the source to the destination in several ways: **ground propagation**, **sky propagation**, and **line-of-sight propagation**, as shown in Figure 6.9.

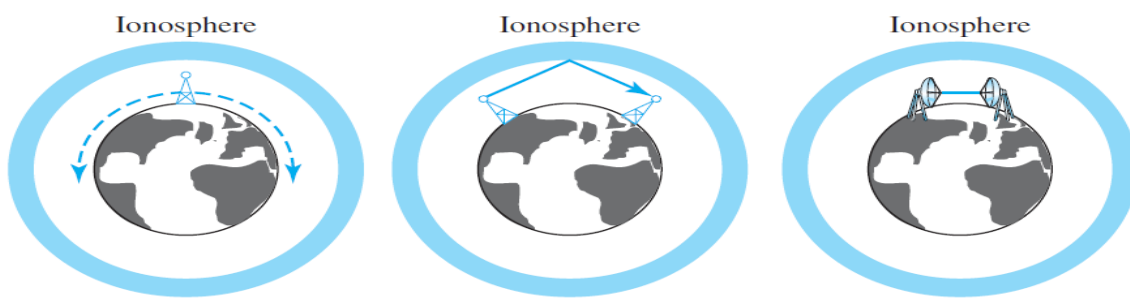

In **ground propagation**, radio waves travel through the lowest portion of the atmosphere, hugging the earth.

In **sky propagation**, higher-frequency radio waves radiate upward into the ionosphere (the layer of atmosphere) where they are reflected back to earth.

In **line-of-sight propagation**, very high-frequency signals are transmitted in straight lines directly from antenna to antenna. Antennas must be directional.

The radio waves and microwaves is divided into eight ranges, called **bands**. These bands are rated from very low frequency (VLF) to extremely high frequency (EHF) as shown in the following table.

<i>Band</i>	<i>Range</i>	<i>Propagation</i>	<i>Application</i>
very low frequency (VLF)	3–30 kHz	Ground	Long-range radio navigation
low frequency (LF)	30–300 kHz	Ground	Radio beacons and navigational locators
middle frequency (MF)	300 kHz–3 MHz	Sky	AM radio
high frequency (HF)	3–30 MHz	Sky	Citizens band (CB), ship/aircraft
very high frequency (VHF)	30–300 MHz	Sky and line-of-sight	VHF TV, FM radio
ultrahigh frequency (UHF)	300 MHz–3 GHz	Line-of-sight	UHF TV, cellular phones, paging, satellite
superhigh frequency (SHF)	3–30 GHz	Line-of-sight	Satellite
extremely high frequency (EHF)	30–300 GHz	Line-of-sight	Radar, satellite

فقط للإطلاع

## 6.5.4 Radio Waves

**Radio waves** are **omnidirectional**, when an antenna transmits radio waves; they are propagated in all directions. *This means* that the sending and receiving antennas **do not have to be aligned**, and makes them useful for multicasting in which there is one sender and many receivers. **AM radio, FM radio and television are examples of multicasting.** Figure 6.10 shows an omnidirectional antenna.





Radio waves, particularly those waves that **propagate in the sky mode**, can travel **long distances**. This makes radio waves a good candidate **for long-distance broadcasting such as AM radio**. Radio waves **can penetrate walls**.

### 6.5.5 Microwaves

Microwaves are **unidirectional**. **Microwave propagation is line-of-sight**. Since the towers with the mounted antennas need to be in direct sight of each other. Microwaves need unidirectional antennas that send out signals in one direction. Two **types of antennas** are used for microwave communications: the **dish antenna** and the **horn antenna** (see Figure 6.11). The sending and receiving antennas **need to be aligned**. Repeaters are often needed for long distance communication. Microwaves, due to their unidirectional properties, are very useful when **unicast** (one-to-one) communication is needed between the sender and the receiver. They are used in **cellular phones, satellite networks, and wireless LANs**. Very high-frequency microwaves **cannot penetrate walls**.

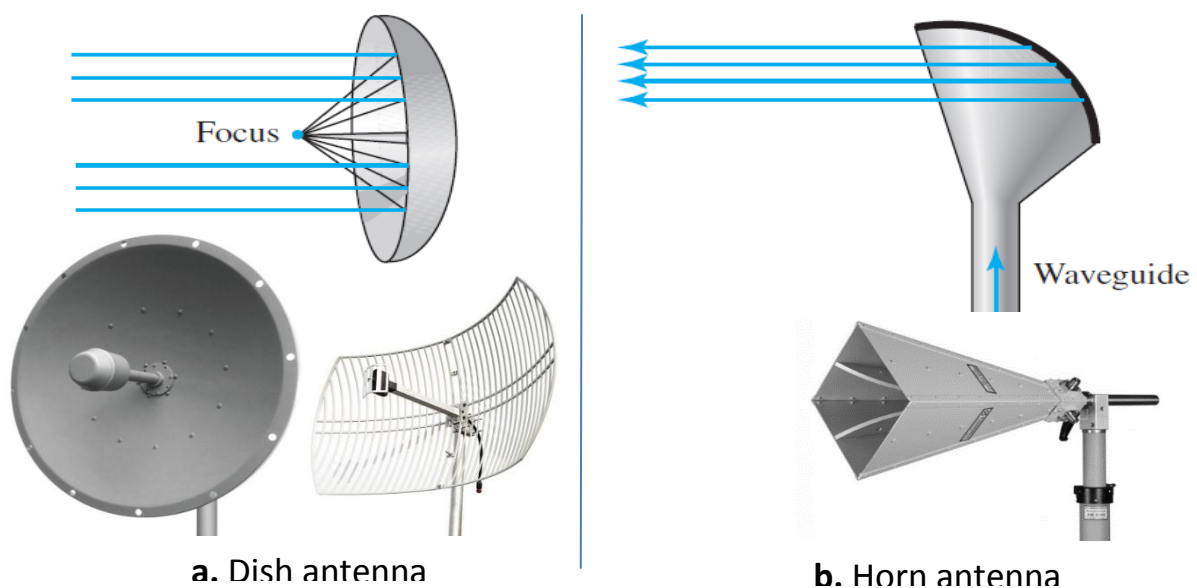

**Figure 6.11** Unidirectional antennas

### 6.5.6 Infrared waves

Infrared waves with frequencies from 300 GHz to 400 THz can be used for **short-range communication**.

Infrared waves, having high frequencies, **cannot penetrate walls**. This **advantageous characteristic** prevents interference between one system and another. When we use our infrared remote control, we do not interfere with the use of the remote by our neighbours. The infrared waves cannot be used outside a building **because** the sun's rays contain infrared waves that can interfere with the communication. The infrared band, almost 400 THz, has an excellent potential for data transmission. Such a wide bandwidth can be used to transmit digital data with a very high data rate.

The **Infrared Data Association** (IrDA), an association which has established standards for using these signals for communication between devices such as **keyboards, mice, PCs, and printers**. Infrared signals defined by IrDA transmit through **line of sight**; the IrDA port on the keyboard needs to point to the PC for transmission to occur.





Baghdad University  
Collage of Ibn-Al-Haitham for Pure  
Science  
Department of Computer Science



جامعة بغداد  
كلية التربية للعلوم الصرفة / ابن الهيثم  
قسم علوم الحاسبات

المرحلة الرابعة

صباحي + مسائي

(شبكات واتصالات - محاضرات النظري)

ملزمة رقم 7

## Data communication and Networks

### Chapter 7: IP addressing

Dr. Mohammed Kamal Nsaif

Dr. Wisal Hashim Abdulsalam

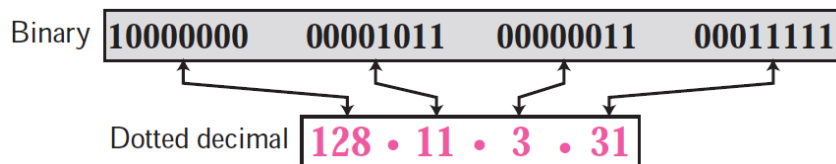

## 7. IPv4 address

The identifier used in the IP layer of the TCP/IP protocol suite to identify each device connected to the Internet is called the **Internet address** or **IP address**. An **IPv4 address** is a 32-bit address that *uniquely and universally* defines the connection of a host or a router to the Internet.

Two devices on the Internet can **never have** the *same address* at the same time. However, if a device has two connections to the Internet, via two networks, **it has two IPv4 addresses**.

### 7.1 Address Space

An address space is the total number of addresses used by the protocol. If a protocol uses  $b$  bits to define an address, the address space is  $2^b$  because each bit can have two different values (0 or 1). IPv4 uses 32-bit addresses, which means that the address space is  $2^{32}$  or 4,294,967,296 (more than four billion). Theoretically, if there were no restrictions, more than 4 billion devices could be connected to the Internet.

### 7.2 Notation

There are three common notations to show an IPv4 address: binary notation (base 2), dotted-decimal notation (base 256), and hexadecimal notation (base 16).

#### Binary Notation: Base 2

In binary notation, an IPv4 address is displayed as 32 bits (in four octets). Each octet (8 bits) is often referred to as a byte. The following is an example of an IPv4 address in binary notation:

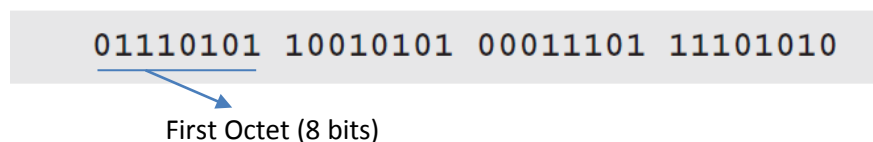

#### Dotted-Decimal Notation: Base 256

To make the IPv4 address more compact and easier to read, an IPv4 address is usually written in decimal form with a decimal point (dot) separating the bytes.

Note that because each byte (octet) is only 8 bits, each number in the dotted-decimal notation is between 0 and 255 (see Figure 7.1).

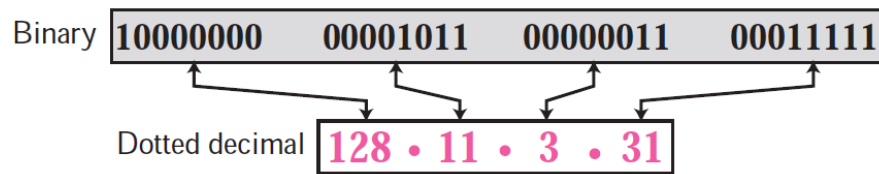

**Figure 7.1** Dotted-decimal notation

### Example 1

Change the following IPv4 addresses from binary notation to dotted-decimal notation.

- a. 10000001 00001011 00001011 11101111
- b. 11000001 10000011 00011011 11111111

### Solution

We replace each group of 8 bits with its equivalent decimal number and add dots for separation:

- a. 129.11.11.239
- b. 193.131.27.255

### Example 2

Change the following IPv4 addresses from dotted-decimal notation to binary notation.

- a. 111.56.45.78
- b. 221.34.7.82

### Solution

We replace each decimal number with its binary equivalent:

- a. 01101111 00111000 00101101 01001110
- b. 11011101 00100010 00000111 01010010

### Example 3

Find the error, if any, in the following IPv4 addresses:

- a. 111.56.045.78
- b. 221.34.7.8.20
- c. 75.45.301.14
- d. 11100010.23.14.67

### Solution

- a. There should be no leading zeroes in dotted-decimal notation (045).
- b. We may not have more than 4 bytes in an IPv4 address.
- c. Each byte should be less than or equal to 255; 301 is outside this range.
- d. A mixture of binary notation and dotted-decimal notation is not allowed.

## 7.3 Classful addressing

In classful addressing, the IP address space is divided into five classes: A, B, C, D, and E. Each class occupies some part of the whole address space. Figure 7.2 shows the class occupation of the address space.

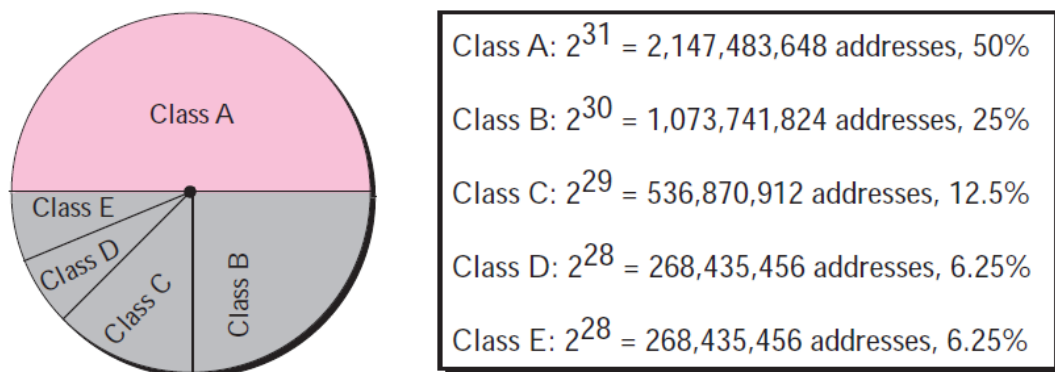

Figure 7.2 Occupation of the address space

### 7.3.1 Recognizing Classes

We can find the class of an address when the address is given either in binary or dotted decimal notation. In the binary notation, the first few bits can

immediately tell us the class of the address; in the dotted-decimal notation, the value of the first byte can give the class of an address (Figure 7.3).

	Octet 1	Octet 2	Octet 3	Octet 4		Byte 1	Byte 2	Byte 3	Byte 4
Class A	0.....				Class A	0-127			
Class B	10.....				Class B	128-191			
Class C	110.....				Class C	192-223			
Class D	1110....				Class D	224-299			
Class E	1111....				Class E	240-255			

Binary notation

Dotted-decimal notation

**Figure 7.3** Finding the class of an address

### Example 5

Find the class of each address:

- 00000001 00001011 00001011 11101111
- 11000001 10000011 00011011 11111111
- 10100111 11011011 10001011 01101111
- 11110011 10011011 11111011 00001111

### Solution

- The first bit is 0. This is a class A address.
- The first 2 bits are 1; the third bit is 0. This is a class C address.
- The first bit is 1; the second bit is 0. This is a class B address.
- The first 4 bits are 1s. This is a class E address.

### Example 6

Find the class of each address:

- 227.12.14.87
- 193.14.56.22
- 14.23.120.8
- 252.5.15.111

### Solution

- The first byte is 227 (between 224 and 239); the class is D.
- The first byte is 193 (between 192 and 223); the class is C.
- The first byte is 14 (between 0 and 127); the class is A.
- The first byte is 252 (between 240 and 255); the class is E.

### 7.3.2 NetId and HostId

In classful addressing, an IP address in classes A, B, and C is divided into NetId and HostId. Figure 7.4 shows the NetId and HostId bytes. Note that classes D and E are not divided into NetId and HostId.

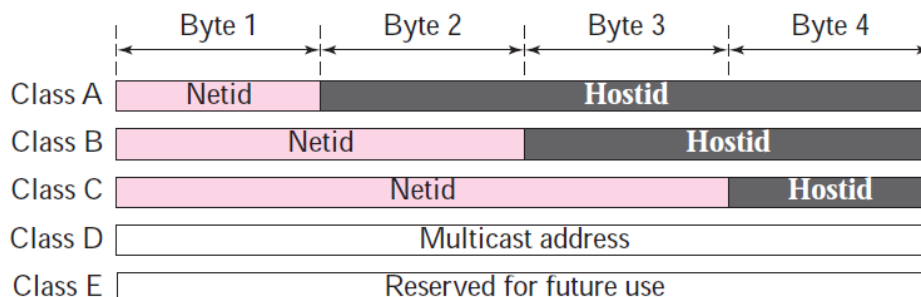
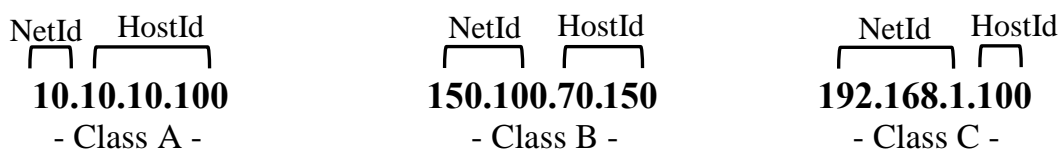

Figure 7.4 NetId and HostId



#### Class D

There is just one block of class D addresses. It is designed for **multicasting**. Each address in this class is used to define **one group of hosts** on the Internet. When a group is assigned an address in this class, every host that is a member of this group will have a multicast address in addition to its normal (unicast) address.

#### Class E

There is just one block of class E addresses. It was designed for use as reserved addresses for **future purposes**.

### 7.3.3 Extracting Information in a Block

The **block size** shows the number of IP addresses contained in a specific range. Given any address in the block, we normally like to know three pieces of information about the block: the number of addresses, the first address, and the last address. After the class of the block is found, **we know the value of n** (the length of NetId in bits). We can now find these three pieces of information as shown in the following:

1. The number of addresses in the block, N, can be found using  $N = 2^{32-n}$ .

2. To find the first address, we keep the  $n$  leftmost bits and set the  $(32 - n)$  rightmost bits all to 0s.
3. To find the last address, we keep the  $n$  leftmost bits and set the  $(32 - n)$  rightmost bits all to 1s.

### Example 7

An address in a block is given as 73.22.17.25. Find the number of addresses in the block, the first address, and the last address.

### Solution

Since 73 is between 0 and 127, the class of the address is A. The value of  $n$  for class A is 8. Figure 7.8 shows a possible configuration of the network that uses this block. Note that we show the value of  $n$  in the network address after a slash.

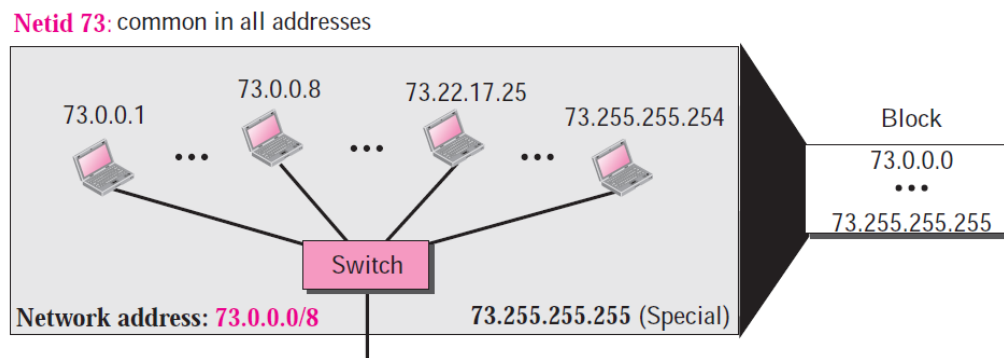

Figure 7.8 Solution to Example 7

1. The number of addresses in this block is  $N = 2^{32-n} = 2^{24} = 16,777,216$ .
2. The first address is 73.0.0.0/8 in which 8 is the value of  $n$ . The first address is called the **network ID** and is not assigned to any host. It is used to define the network.
3. The last address is 73.255.255.255. The last address (or called the **broadcast ID**) is normally used for a special purpose.

### Example 8

An address in a block is given as 180.8.17.9. Find the number of addresses in the block, the first address, and the last address.

### Solution

1. The number of addresses in this block is  $N = 2^{32-n} = 2^{16} = 65,536$ .

- The first address (network address) is 18.8.0.0/16, in which 16 is the value of n.
- The last address is 18.8.255.255.

### Example 9

Figure 7.9 shows a hypothetical part of an internet with three networks.

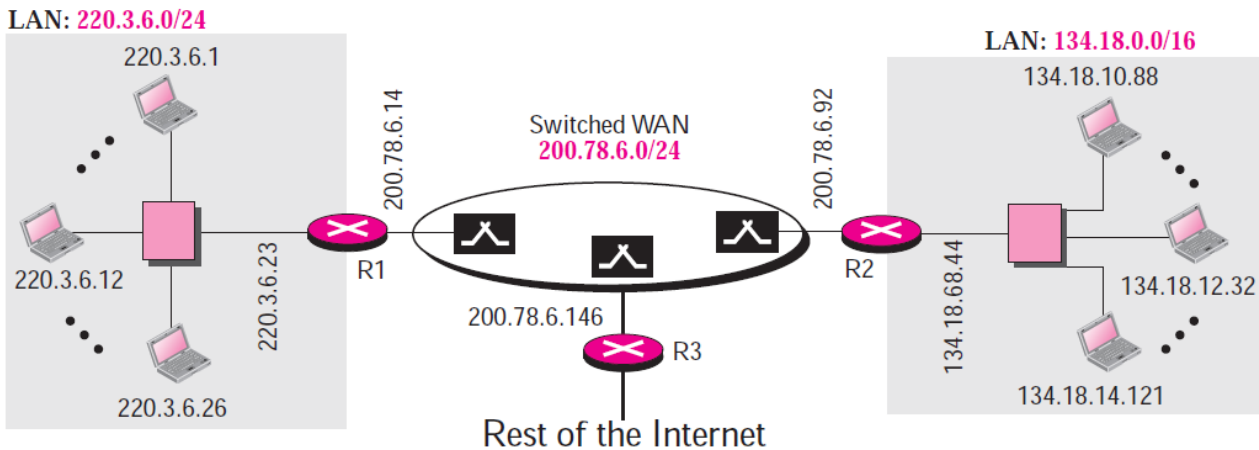

**Figure 7.9** Sample internet

We have

- A LAN with the network address 220.3.6.0 (class C).
- A LAN with the network address 134.18.0.0 (class B).
- A switched WAN (class C), that can be connected to many routers. We have shown three. One router connects the WAN to the left LAN, one connects the WAN to the right LAN, and one connects the WAN to the rest of the internet.

## 7.4 Network Mask

A **network mask** or a **default mask** in classful addressing is a 32-bit number with **n** leftmost bits all set to 1s and (32 – n) rightmost bits all set to 0s. Since n is different for each class in classful addressing, we have three default masks in classful addressing as shown in Figure 7.10.

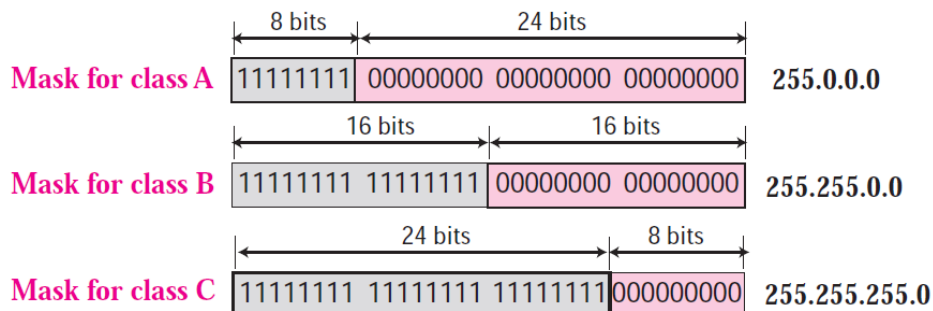

**Figure 7.10** Network mask



The routers in the Internet normally use an algorithm to extract the network address from the destination address of a packet. A router uses the AND operation. When the destination address is ANDed with the default mask, the result is the network address.

### Example 10

A router receives a packet with the destination address 201.24.67.32. Show how the router finds the network address of the packet.

### Solution

Since the class of the address is C, we assume that the router applies the default mask for class B, 255.255.255.0 to find the network address.

The destination address is ANDed with the default mask as described in the previous section. The network address (or ID) is 201.24.67.0.

## 7.5 Special Addresses

Some blocks of addresses are **reserved for special purposes** and cannot be used as normal IP addresses as shown in the following:

**1- All-Zeros Address** The block **0.0.0.0/32**, which **contains only one single address**, is reserved for communication when a host needs to send an IPv4 packet but it does not know its own address. The host sends an IPv4 packet to a bootstrap server (called DHCP server) using this address as the source address and a **limited broadcast address (255.255.255.255)** as the destination address to find its own address (see figure 7.11).

**2- All-Ones Address** The block **255.255.255.255/32**, which contains one single address, is reserved for **limited broadcast address** in the current network.

**3- Loopback Addresses** The block 127.0.0.0/8 is used **to test** the software on a machine. When this address is used, **a packet never leaves the machine**; it simply returns to the protocol software.

**4- Network ID and broadcast ID** As we have already discussed, the network ID is the first address (with the suffix set all to 0s) in a block **defines the network address**. Broadcast ID is the last address in a block or subnet (with the suffix set all to 1s) can be used as a direct broadcast address. **This address is usually used by a router to send a packet to all hosts in a specific network.**

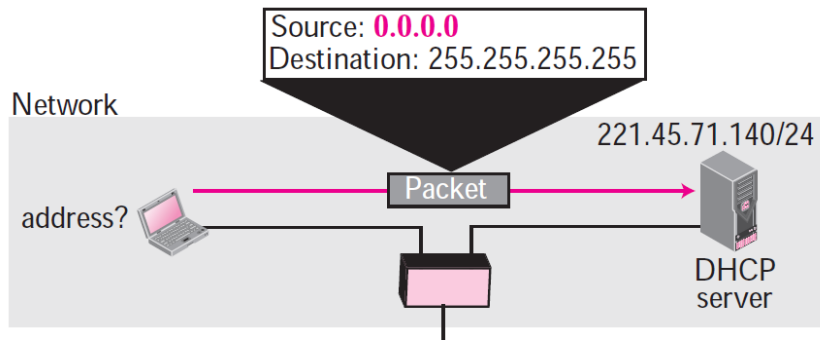

**Figure 7.11** Examples of using the all-zeros and all-ones addresses

## 7.6 Internet Protocol version 6 (IPv6)

IPv6 was developed to deal with the problem of IPv4 address. IPv6 **is intended to replace** IPv4. With the rapid growth of the Internet after the 1990s, far more addresses would be needed to connect devices than the IPv4 address space had available.

By 1998, the IPv6 had been formalized with **128-bit**, theoretically allowing  $2^{128}$ , or approximately  $3.4 \times 10^{38}$  addresses, whereas IPv4 uses only **32-bit** addresses and provides approximately  $2^{32}$ , or 4.3 billion addresses.

IPv6 addresses are represented as **eight groups of four hexadecimal digits** with the groups being separated by colons, for example

3501:0cb8:0000:0052:0000:7a5e:0b70:9335

But methods are existed to abbreviate this full notation as shown in Figure 7.12.

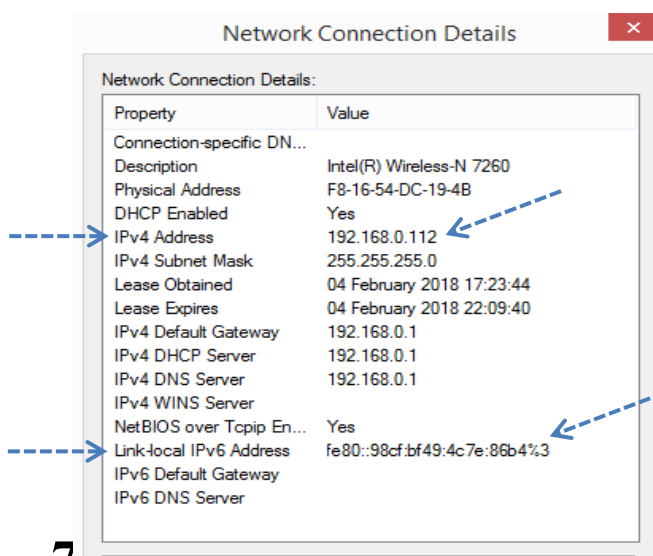

**Figure 7.12** Example of IPv6 and IPv4 addresses in a host

7.7 Subnetting

Subnetting is a process of breaking large network in small networks known as **subnets**.

## **Method of subnetting**

In subnetting we need to find the following:

### **a. Finding the subnet mask**

To find the subnet mask, we 1) need to write down the default subnet mask, 2) find the host bits borrowed to create subnets, and 3) put the borrowed bits (1s bits) in the left side instead of the 0s bits.

For example: find the subnet mask of address 188.25.45.48/20

1. The default subnet mask is 255.255.0.0 (/16),
2. The number of borrowed bits from HostId portion is 4 (20 - 16 = 4).
3. The subnet mask in binary would be 11111111. 11111111. 11110000. 00000000.

Then subnet mask in decimal is **255.255.240.0**

IP address: 188.25.45.48/20      subnet mask: 255.255.240.0

### **b. Finding the number of subnets**

To calculate the number of subnets (sub-networks) provided by given subnet mask we use  $2^b$ , where b = number of bits borrowed from HostId bits to create subnets.

For example: find the number of subnets in 192.168.1.0/27

The number of borrowed bits is 3 because 27-24=3. (24 is the default value of Class C IP).

Then the number of subnets is  $2^3 = 8$

This means that we can make 8 sub-networks with the IP rang 192.168.1.0/27.

### **c. Finding the total hosts**

Total hosts are the hosts available per subnet.  $2^H = \text{Total hosts}$ . H is the number of host bits. For example in address 192.168.1.0/26 we have 32 - 26 = 6 (where 32 is the total bits in IP address). Total hosts per subnet would be  $2^6 = 64$ .

### Valid number of hosts

As we mentioned previously, we need to reduce two addresses per block (or subnet), one for network ID and another for broadcast ID. Therefore,

$$\text{Valid hosts} = \text{Total hosts} - 2.$$

In above example we have 64 hosts per subnet, so valid hosts in each subnet would be  $64 - 2 = 62$ .

network ID → 192.168.1.0	broadcast ID → 192.168.1.63	(First subnet)
network ID → 192.168.1.64	broadcast ID → 192.168.1.127	(Second subnet)
network ID → 192.168.1.128	broadcast ID → 192.168.1.191	(Third subnet)
network ID → 192.168.1.192	broadcast ID → 192.168.1.255	(Forth subnet)

In the following we include some examples only from class C (**Class C Subnetting**).

**Example 11** assume an organization has purchased the IP range: 192.168.55.0 and they need to use this IP range through four buildings with 55 host computer in each building. Find the 1) suitable subnet mask, 2) number of subnet, 3) number of hosts in each subnet, 4) valid number of hosts, 5) the network ID, broadcast ID for third subnet, and unused IPs of the third subnet.

#### Solution

Because we need to distribute the IP range through four buildings or networks, then the number of bits that will be borrowed from HostId is 2 as shown in the following:

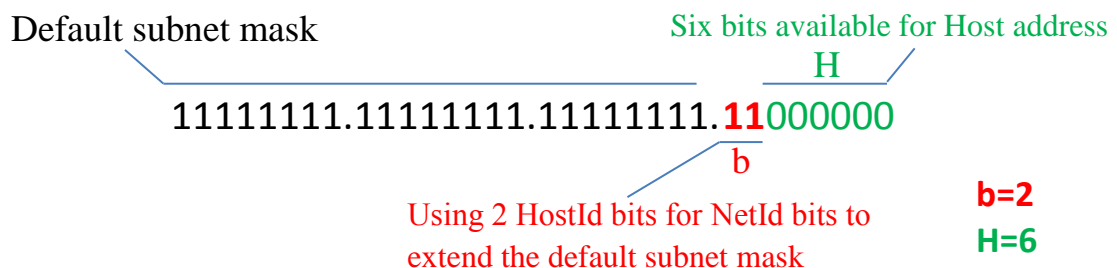

Decimal notation for the subnet mask: 255.255.255.192 (/26)

- 1) Subnet mask: 255.255.255.192 (/26) IP address: 192.168.55.0/26
- 2) Number of subnet:  $2^b = 2^2 = 4$
- 3) Number of host in each subnet:  $2^H = 2^6 = 64$  available hosts
- 4) Valid number of hosts:  $64 - 2 = 62$
- 5) Network ID → 192.168.55.128, broadcast ID → 192.168.55.191 (for third subnet)  
Unused IP addresses =  $62 - 55 = 7$

**Example 12** assume that we have the IP address 200.10.73.0/28, find each of following: Find the 1) subnet mask, 2) number of subnets, 3) number of hosts in each subnet, 4) valid number of hosts, 5) the network ID, broadcast ID of the second subnet.

**Solution**

The **binary notation** for the subnet mask is as shown below:

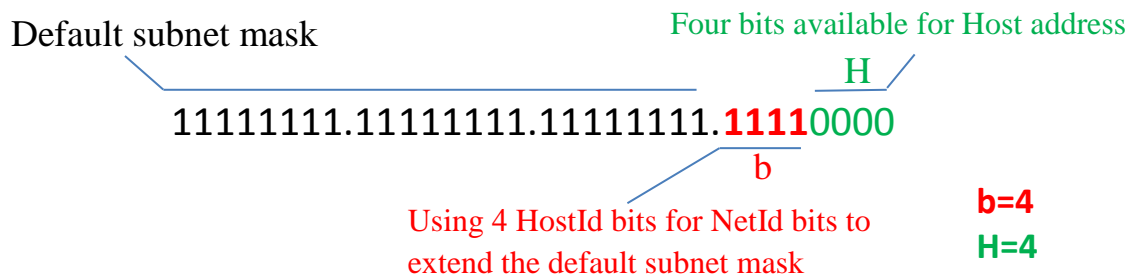

**Binary notation** for the subnet mask: 255.255.255.240 (/28)

- 1) Subnet mask: 255.255.255.240 (/28) IP address: 200.10.73.0/28
- 2) Number of subnets:  $2^b = 2^4 = 16$
- 3) Number of host in each subnet:  $2^H = 2^4 = 16$  available hosts
- 4) Valid number of hosts:  $16-2=14$
- 5) Network ID → 200.10.73.16, broadcast ID → 200.10.73.31 (for second subnet)

## Wired LANs –Ethernet–

The Computer Society of the IEEE started a project, called *Project 802*, to set standards to enable intercommunication among equipment from a variety of manufacturers. Project 802 does not seek to replace any part of the OSI model or TCP/IP protocol suite. The relationship of the 802 Standard to the TCP/IP protocol suite is shown in Figure 8.1. The IEEE has subdivided the data-link layer into two sub-layers: **logical link control (LLC)** and **media access control (MAC)**.

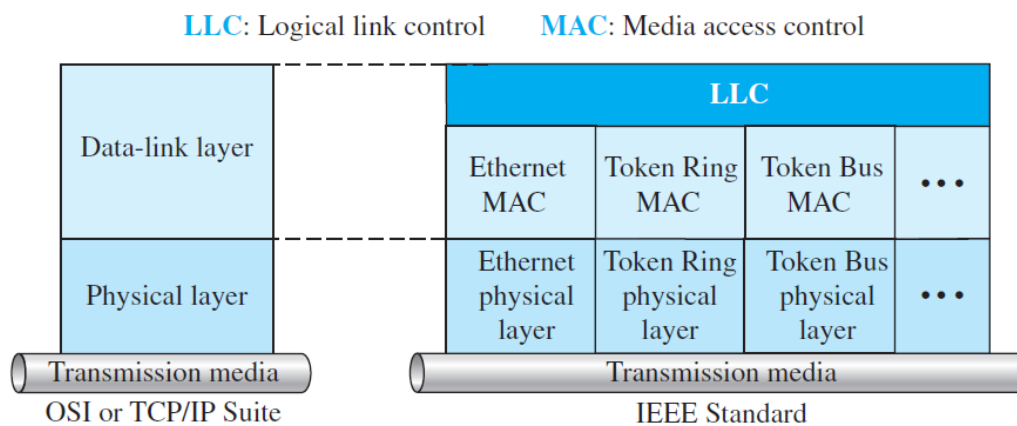

**Figure 8.1** IEEE standard for LANs

## Ethernet Evolution

The Ethernet LAN was developed in the 1970s by Robert Metcalfe and David Boggs. Since then, it has gone through four generations: **Standard Ethernet** (10 Mbps), **Fast Ethernet** (100 Mbps), **Gigabit Ethernet** (1 Gbps), and **10 Gigabit Ethernet** (10 Gbps), as shown in Figure 8.2.

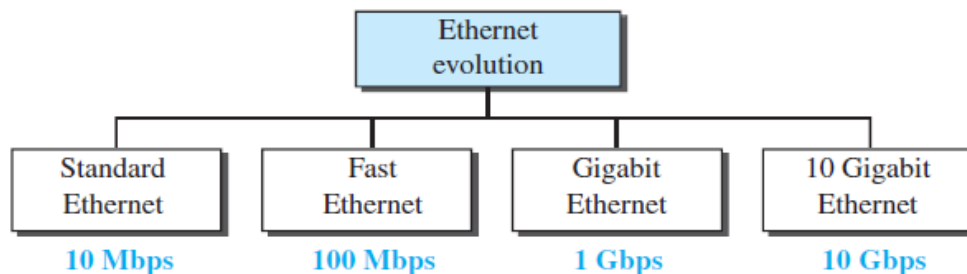

**Figure 8.2** Ethernet evolutions through four generations

## 8.1 Standard Ethernet

We refer to the original Ethernet technology with the data rate of 10 Mbps as the **Standard Ethernet**. Although most implementations have moved to other technologies in the Ethernet evolution, there are some features of the Standard Ethernet that have not changed during the evolution.

### 8.1.1. Addressing

Each station on an Ethernet network (such as a PC, workstation, or printer) has its own **network interface card (NIC)**. The NIC fits inside the station and provides the station with a link-layer address. The Ethernet address is 6 bytes (48 bits), normally written in hexadecimal notation. For example, the following shows an Ethernet MAC address:

4A:30:10:21:10:1A

### Transmission of Address Bits

The transmission is left to right, **byte by byte**; however, for each byte, the least significant **bit** is sent first and the most significant **bit** is sent last. This means that the bit that defines an address as unicast or multicast arrives first at the receiver. This helps the receiver to immediately know if the packet is unicast or multicast.

#### Example 1

Show how the address 47:20:1B:2E:08:EE is sent out online.

#### Solution

The address is sent **left to right**, *byte by byte*. But for each byte, it is sent **right to left**, *bit by bit*, as shown below:

Hexadecimal	47	20	1B	2E	08	EE
Binary	01000111	00100000	00011011	00101110	00001000	11101110
Transmitted ←	11100010	00000100	11011000	01110100	00010000	01110111

### Unicast, Multicast, and Broadcast Addresses

A **source address** is always a *unicast address*—the frame comes from only one station. The **destination address**, however, can be *unicast*, *multicast*, or

*broadcast*. Figure 8.3 if the least significant bit of the first byte in a destination address is 0, the address is unicast; otherwise, it is multicast. The broadcast address is a special case of the multicast address. A broadcast destination address is forty-eight 1s.

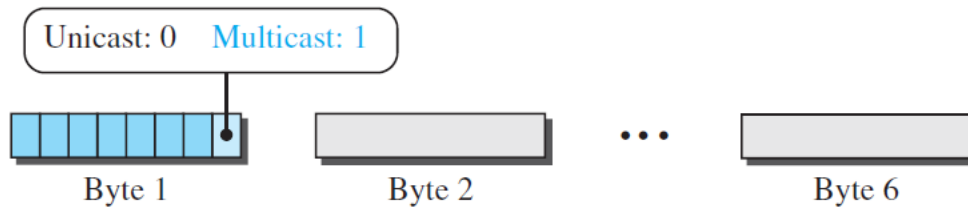

**Figure 8.3** Unicast and multicast addresses

### Example 2

Define the type of the following destination addresses:

- a. 4A:30:10:21:10:1A
- b. 47:20:1B:2E:08:EE
- c. FF:FF:FF:FF:FF:FF

### Solution

To find the type of the address, we need to look at the second hexadecimal digit from the left. If it is even, the address is unicast. If it is odd, the address is multicast. If all digits are Fs, the address is broadcast. Therefore, we have the following:

- a. This is a unicast address because A in binary is 1010 (even).
- b. This is a multicast address because 7 in binary is 0111 (odd).
- c. This is a broadcast address because all digits are Fs in hexadecimal.

### Distinguish Between Unicast, Multicast, and Broadcast Transmission

Standard Ethernet uses a coaxial cable (bus topology) or a set of twisted-pair cables with a hub (star topology) as shown in Figure 8.4.

We need to know that transmission in the standard Ethernet is always broadcast, no matter if the intention is unicast, multicast, or broadcast. In the bus topology, when station A sends a frame to station B, all stations will receive it. In the star topology, when station A sends a frame to station B, the hub will receive it.



Since the hub is a passive element, it regenerates the bits and sends them to all stations except station A.

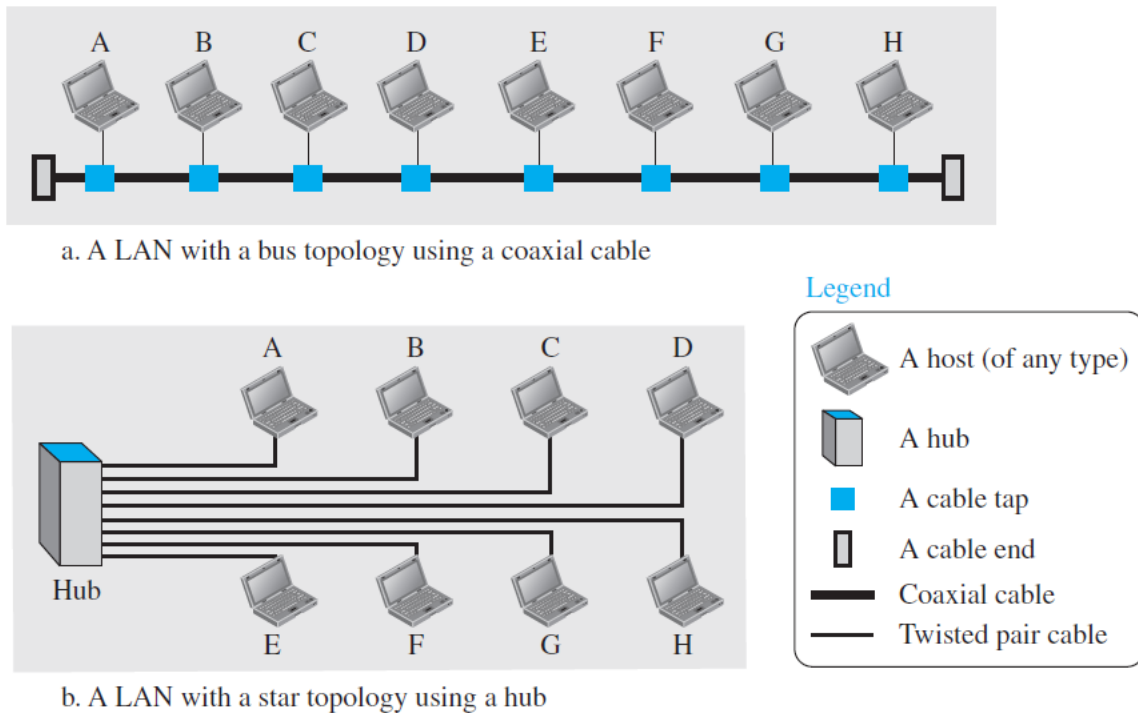

**Figure 8.4** Implementation of standard Ethernet

The question is, then, how the actual unicast, multicast, and broadcast transmissions are distinguished from each other. The answer is in the way the frames are **kept or dropped**.

- In a unicast transmission, all stations will receive the frame, the **intended recipient** keeps and handles the frame; the rest discard it.
- In a multicast transmission, all stations will receive the frame, the stations that are **members of the group** keep and handle it; the rest discard it.
- In a broadcast transmission, all stations (except the sender) will receive the frame and **all stations** (except the sender) keep and handle it.

### 8.1.2 Access Method

Since the network that uses the standard Ethernet protocol is a broadcast network, we need to use an access method to control access to the sharing medium. The standard Ethernet uses the protocol CSMA/CD as an access method.

ان الـ CSMA/CD هو اختصار لـ Carrier Sense Multiple Access with Collision Detection وهو بروتوكول يتغلب على مشكلة التصادم (collision) و التي تحدث نتيجة ارسال بيانات من قبل عدد من الـ hosts في نفس الوقت.

كيف يعمل الـ CSMA/CD ؟

يقوم الجهاز المرسل (Host) الذي يرغب بارسال البيانات بالتأكد من وجود اشارة في الواير او عدم وجودها ( كما نعلم فان البيانات ترسل في النهاية كاشارة كهربائية ) ، في حالة عدم وجود اشارة فانه يبدأ بالارسال ويستمر في نفس الوقت بمراقبة الواير للتأكد من عدم وصول اشارة ثانية ، في حالة اكتشافها لوجود اشارة ثانية ( اي ان host اخر بدأ بعملية ارسال بيانات ) فانه سيتوقف عن الارسال وترسل jam signal وهي عبارة عن اشارة تبلغ جميع الـ hosts بحدوث الـ collision فتتوقف جميع الـ hosts عن ارسال البيانات لفترة زمنية خاصة بكل host لتجنب حدوث الـ collision مرة اخرى عند معاودة الارسال. عند انتهاء الفترة الزمنية للـ host الاول فانه يعاود عملية ارسال البيانات الى ان تنتهي فترة التوقف للـ host الثاني والذي ايضا يعاود الارسال مرة اخرى بعد ان انتهى الـ host الاول من الارسال وبالتالي تجنبنا حدوث التصادم مرة اخرى.

### 8.1.3 Implementation

The Standard Ethernet defined several implementations, but only four of them became popular during the 1980s. Table 8.1 shows a summary of Standard Ethernet implementations.

Implementation	Medium	Medium Length
10Base5	Thick coax	500 m
10Base2	Thin coax	185 m
10Base-T	2 UTP	100 m
10Base-F	2 Fiber	2000 m

**Table 8.1** Summary of Standard Ethernet implementations

In the term 10BaseX, the number defines the data rate (10 Mbps), the term *Base* means baseband (digital) signal, and X approximately defines either the maximum size of the cable in 100 meters (for example 5 for 500 or 2 for 185 meters) or the type of cable, T for unshielded twisted pair cable (UTP) and F for fiber-optic. The standard Ethernet uses a baseband signal, which means that the bits are changed to a digital signal and directly sent on the line.

## 8.2 Fast Ethernet (100 Mbps)

Ethernet made a big jump by increasing the transmission rate to 100 Mbps, and the new generation was called the *Fast Ethernet*. The designers of the Fast

Ethernet needed to make it compatible with the Standard Ethernet. The goals of Fast Ethernet can be summarized as follows:

1. Upgrade the data rate to 100 Mbps.
2. Make it compatible with Standard Ethernet.  
and other goals.

### 8.2.1 Access Method

Fast Ethernet is 10 times faster than Standard Ethernet. In order to achieve this, the Fast Ethernet came with two solutions (it can work with either choice):

1. The first solution was to totally drop the bus topology and use a passive hub and star topology but make the maximum size of the network 250 meters instead of 2500 meters as in the Standard Ethernet. This approach is kept for compatibility with the Standard Ethernet.
2. The second solution is to use a link-layer switch (instead of physical-layer hub) with a buffer to store frames and a full-duplex connection to each host to make the transmission medium private for each host. In this case, there is no need for CSMA/CD because the hosts are not competing with each other.

### 8.2.2 Implementation

Fast Ethernet implementation at the physical layer can be categorized as either two-wire or four-wire. The two-wire implementation can be either shielded twisted pair (STP), which is called *100Base-TX*, or fiber-optic cable, which is called *100Base-FX*. The four-wire implementation is designed for unshielded twisted pair (UTP), which is called *100Base-T4* (see Table 8.2).

<i>Implementation</i>	<i>Medium</i>	<i>Medium Length</i>	<i>Wires</i>
100Base-TX	UTP or STP	100 m	2
100Base-FX	Fiber	185 m	2
100Base-T4	UTP	100 m	4

**Table 8.2** Summary of Fast Ethernet implementations

## 8.3 Gigabit Ethernet

The need for an even higher data rate resulted in the design of the Gigabit Ethernet Protocol (1000 Mbps). The IEEE committee calls it the Standard **802.3z**. The goals of the Gigabit Ethernet design can be summarized as follows:

1. Upgrade the data rate to 1 Gbps.
2. Make it compatible with Standard or Fast Ethernet.  
and other goals.

## Implementation

Table 8.3 is a summary of the Gigabit Ethernet implementations. S-W and L-W mean short-wave and long-wave respectively.

<i>Implementation</i>	<i>Medium</i>	<i>Medium Length</i>	<i>Wires</i>
1000Base-SX	Fiber S-W	550 m	2
1000Base-LX	Fiber L-W	5000 m	2
1000Base-CX	STP	25 m	2
1000Base-T4	UTP	100 m	4

**Table 8.3** Summary of Gigabit Ethernet implementations

## 8.4 10 Gigabit Ethernet

In recent years, there has been another look into the Ethernet for use in metropolitan areas. The idea is to extend the Ethernet, such that it can be used as LAN and MAN. The IEEE committee created 10 Gigabit Ethernet and called it Standard **802.3ae**.

The goals of the 10 Gigabit Ethernet design can be summarized as upgrading the data rate to 10 Gbps. This data rate is possible only with fiber-optic technology at this time.

### Implementation

10 Gigabit Ethernet operates only in full-duplex mode, which means there is no need for contention i.e., CSMA/CD is not used in 10 Gigabit Ethernet. Table 8.4 shows the summary of the 10 Gigabit Ethernet implementations.

<i>Implementation</i>	<i>Medium</i>	<i>Medium Length</i>	<i>Number of wires</i>
10GBase-SR	Fiber 850 nm	300 m	2
10GBase-LR	Fiber 1310 nm	10 Km	2
10GBase-EW	Fiber 1350 nm	40 Km	2
10GBase-X4	Fiber 1310 nm	300 m to 10 Km	2

**Table 8.4** Summary of 10 Gigabit Ethernet implementations

## 9. Wireless LANs –WiFi–

Wireless communication is one of the fastest-growing technologies. The demand for connecting devices without the use of cables is increasing everywhere. In the following three sections, we make three comparisons between wired and wireless LANs depending on architecture, characteristics and access control.

### 9.1 Architectural Comparison

Let us compare the architecture of wired and wireless LANs to give some idea about the following issues:

#### Medium

In a wired switched LAN, with a link-layer switch, the communication between the hosts is **point-to-point** and **full-duplex** (bidirectional). In a wireless LAN, the medium is air, the signal is generally **broadcast**. When hosts in a wireless LAN communicate with each other, they are **sharing the same medium** (multiple access).

#### Hosts

In a wired LAN, before the host can use the services of the Internet, it needs to be physically connected to the Internet. In a wireless LAN, a host is not physically connected to the network; it can move freely and can use the services provided by the network. Therefore, the mobility are totally different issues.

#### Isolated LANs

A wired isolated LAN is a set of hosts connected via a link-layer switch (in the recent generation of Ethernet). A wireless isolated LAN, called an *ad hoc network* in wireless LAN terminology, is a set of hosts that communicate freely with each other. The concept of a link-layer switch does not exist in wireless LANs. Figure 9.1 shows two isolated LANs, one wired and one wireless.

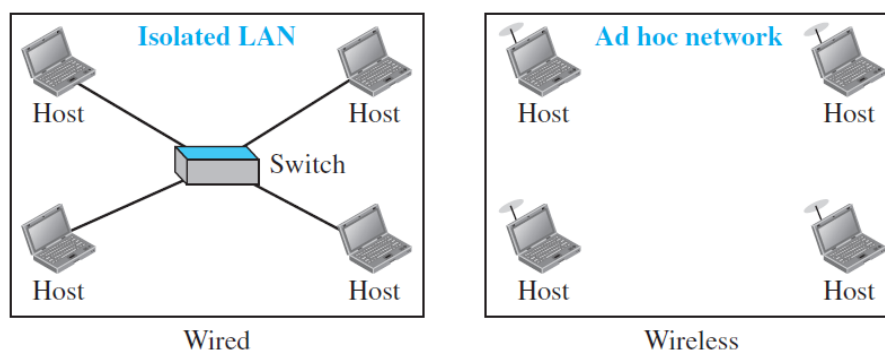
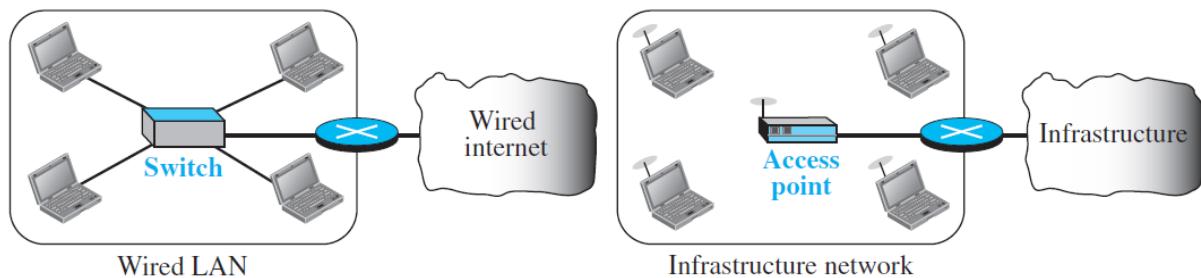

**Figure 9.1** Isolated LANs: wired versus wireless

## Connection to Other Networks

A wired LAN can be connected to another network or an internetwork such as the Internet using a router. In Figure 9.2, the wireless LAN is referred to as an *infrastructure network*, and the connection to the wired infrastructure, such as the Internet, is done via a device called an *access point (AP)*.

Note that the role of the *access point* is **completely different** from the role of a *link-layer switch* in the wired environment. An *access point* is gluing two different environments together: one wired and one wireless.



**Figure 9.2** Connection of a wired LAN and a wireless LAN to other networks

## Moving between Environments

In order to move from the wired environment to a wireless environment, we need to change the network interface cards designed for wired environments to the ones designed for wireless environments and replace the link-layer switch with an access point.

## 9.2 Characteristic Comparison

There are several characteristics of wireless LANs that either do not apply to wired LANs or can be ignored.

### Attenuation

The strength of electromagnetic signals **decreases rapidly** *because* the signal disperses in all directions; only a small portion of it reaches the receiver.

### Interference

Another issue is that a receiver may receive signals not only from the true sender, but also from **other senders** if they are using the same frequency band.

### Multipath Propagation

A receiver may receive more than one signal from the **same sender** because electromagnetic waves can be reflected back from obstacles such as walls, the ground, or objects.

## Error

With the above characteristics of a wireless network, we can expect that errors are **more serious issues** in a wireless network than in a wired network. For example, we can think about the error level in the measurement of **signal-to-noise ratio (SNR)**.

## 9.3 Access control

In the previous chapter, we discussed that the Standard Ethernet (in wired LAN) uses the **CSMA/CD** algorithm. Because of some problems, the **CSMA/CD** does not work in wireless LANs. Therefore, the **Carrier Sense Multiple Access with Collision Avoidance (CSMA/CA)** was invented for wireless LANs.

ان طريقة تفادي التصادم (CSMA/CA) تُستخدم في الشبكات المحلية اللاسلكية وذلك من اجل التحكم بالوصول الى الوسط الناقل. قبل حدوث الارسال، يقوم الجهاز المُرسل Host بالتنصت على الشبكة من اجل تفادي حدوث اصطدام اشارته مع باقي الاشارات التي ممكن ان ترسلها باقي الاجهزة المرتبطة الى الشبكة اللاسلكية في نفس الوقت. فعلى عكس طريقة اكتشاف التصادم (CSMA/CD) التي تتعامل مع البث على الشبكة حالما يتم اكتشاف التصادم، فإن تقنية CSMA/CA هي التعامل مع حركة مرور الاشارات قبل ارسال الإشارة الحقيقية على الشبكة. فالمحطة تبث إشارة من أجل الاستماع إلى احتمال حدوث تصادم وإبلاغ الأجهزة الأخرى بالتوقف عن البث حتى ترسل تلك المحطة إشارات على الشبكة.

## 9.4 IEEE 802.11 project (wireless LAN)

IEEE has defined the specifications for a wireless LAN, called IEEE 802.11, which covers the physical and data-link layers. Some countries, including the United States, use the term WiFi (short for wireless fidelity) as a synonym for wireless LAN.

### 9.4.1 Architecture

The standard defines two kinds of services:

## 1. Basic Service Set

IEEE 802.11 defines the **basic service set (BSS)** as the building blocks of a wireless LAN. A basic service set is made of stationary or mobile wireless stations and an optional central base station, known as the *access point (AP)*. Figure 9.3 shows two sets in this standard.

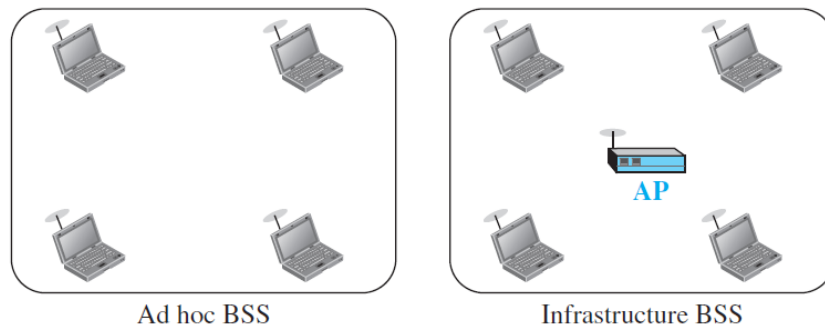
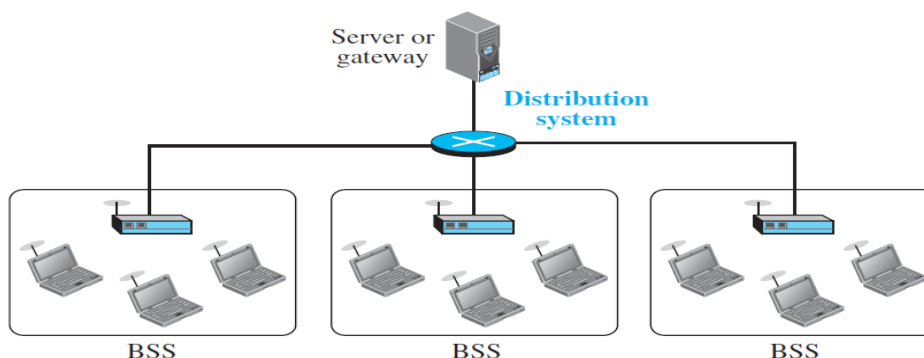

**Figure 9.3** Basic service sets (BSSs)

The BSS without an AP is an independent network and cannot send data to other BSSs. It is called an *ad hoc architecture*. A BSS with an AP is sometimes referred to as an *infrastructure BSS*.

## 2. Extended Service Set

An **extended service set (ESS)** is made up of two or more BSSs with APs. In this case, the BSSs are connected through a *distribution system*, which is a wired or a wireless network. The distribution system connects the APs in the BSSs. Figure 9.4 shows an ESS.



**Figure 9.4** Extended service set (ESS)



## 9.5 Specification of IEEE 802.11

IEEE creates several specifications for the wireless LANs as described in the following:

**IEEE 802.11** In 1997, the IEEE created the first WLAN standard with a maximum network **bandwidth of 2 Mbps** - too slow for most applications.

**IEEE 802.11b** IEEE expanded in July 1999, creating the 802.11b specification. It supports bandwidth up to **11 Mbps**, and uses radio signalling frequency (**2.4 GHz**).

**IEEE 802.11a** was created at the same time of 802.11b, but in a higher cost. IEEE 802.11a is usually found on business networks. It supports bandwidth up to **54 Mbps** and signals in frequency **5 GHz**.

**IEEE 802.11g** was created in 2002 to combine the best of both 802.11a and 802.11b. IEEE 802.11g supports bandwidth up to **54 Mbps**, and it uses the **2.4 GHz** frequency.

**IEEE 802.11n** (or "Wireless N") uses multiple wireless signals and antennas called *MIMO* (multiple-input multiple-output antenna) instead of one. It was created in 2009 with specifications providing for up to **300 Mbps** of network bandwidth.

**IEEE 802.11ac** is the newest generation of Wi-Fi which can utilize dual-band connections on both the 2.4 GHz and 5 GHz Wi-Fi bands. It offers bandwidth rated up to **1300 Mbps on the 5 GHz** band plus up to **450 Mbps on 2.4 GHz**.



WR543G Wireless AP/Client Router **IEEE 802.11b/g**



TP-LINK TL-WR940N **IEEE 802.11n** Wireless Router



LINKSYS WRT54G WIRELESS G  
BROADBAND ROUTER **54Mbps**  
**IEEE 802.11g** 4Router 2.4 GHz)



Asus RT-AC3200 **IEEE 802.11ac**  
Ethernet Wireless Router **2.4, 5 GHz**