

Chapter one

MATLAB

Computer

Chapter one

MATLAB

MATLAB Introduction

- MATLAB is a program for doing numerical computation.
- It was originally designed for solving linear algebra type problems using matrices.
- It's name is derived from MATrix LABoratory.
- MATLAB has since been expanded and now has built-in functions for solving problems requiring data analysis, signal processing, optimization, and several other types of scientific computations.
- It also contains functions for 2-D and 3-D graphics and animation.
- Matlab is basically a high level language which has many specialized toolboxes for making things easier for us
- How high?

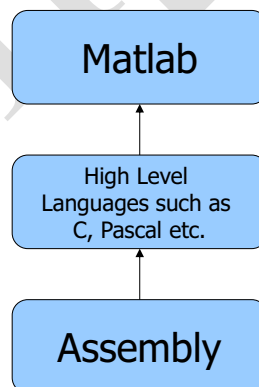

What are we interested in?

- Matlab is too broad for our purposes in this course.
- The features we are going to require is

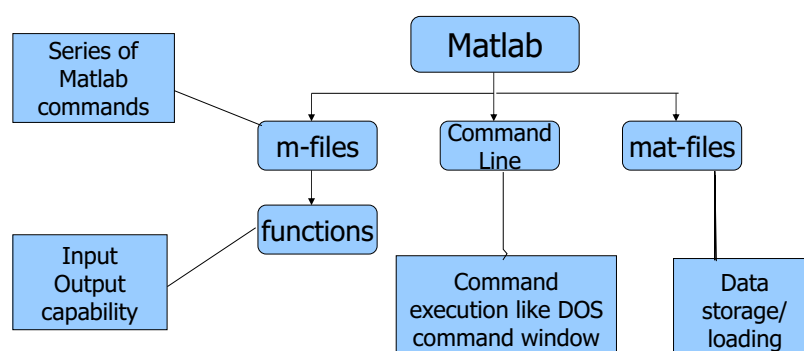

Matlab Screen

Command Window

- Type commands

Current Directory

- View folders and m-files

Workspace

- View program variables
- Double click on a variable to see it in the Array Editor

Command History

- View past commands
- Save a whole session using diary

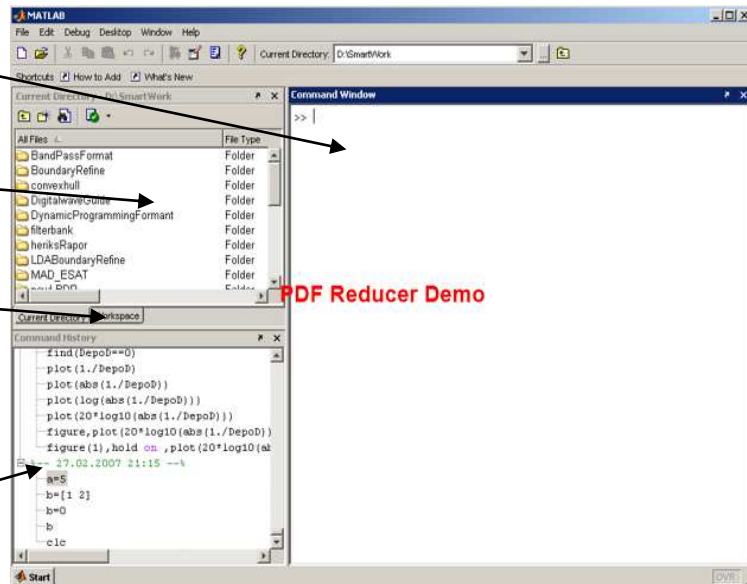

MATLAB Help

- MATLAB Help is an extremely powerful assistance to learning MATLAB
- Help not only contains the theoretical background, but also shows demos for implementation
- MATLAB Help can be opened by using the HELP pull-down menu

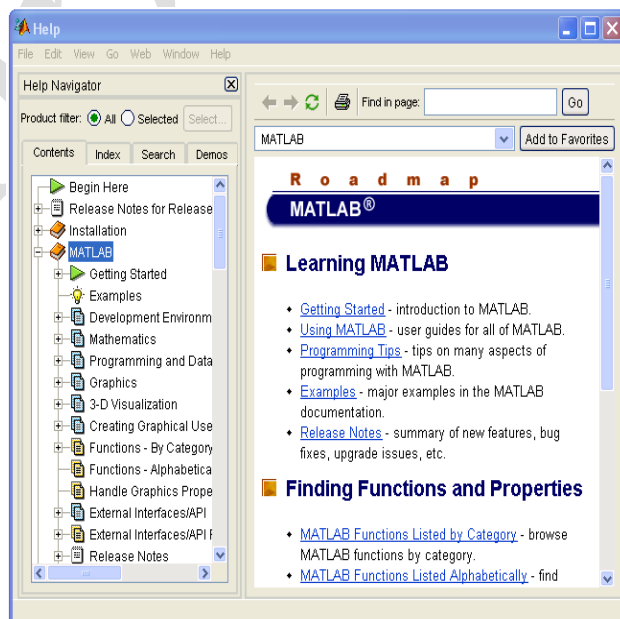

- Any command description can be found by typing the command in the search field
- As shown above, the command to take square root (sqrt) is searched
- We can also utilize MATLAB Help from the command window as shown

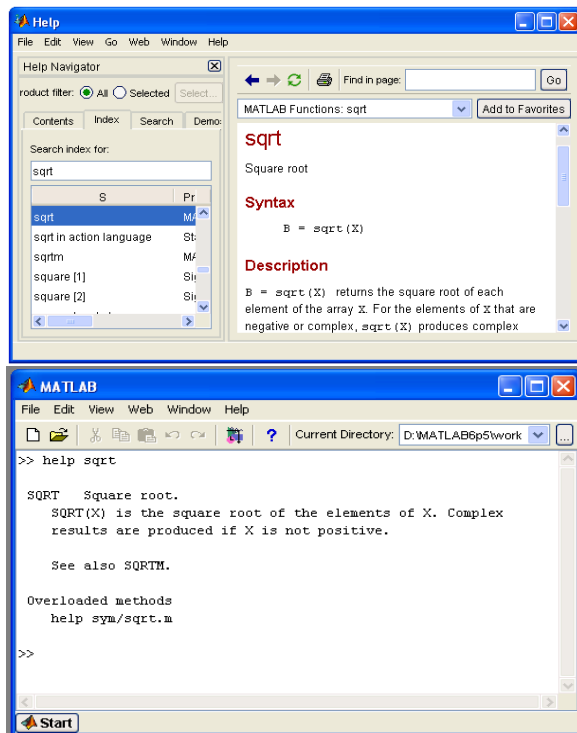

MATLAB Toolboxes

- Statistics Toolbox
- Optimization Toolbox
- Database Toolbox
- Parallel Computing Toolbox
- Image Processing Toolbox
- Bioinformatics Toolbox
- Fuzzy Logic Toolbox
- Neural Network Toolbox
- Data Acquisition Toolbox
- MATLAB Report Generator
- Signal Processing
- Communications
- System Identification
- Wavelet Filter Design
- Control System
- Robust Control

Connecting to MATLAB

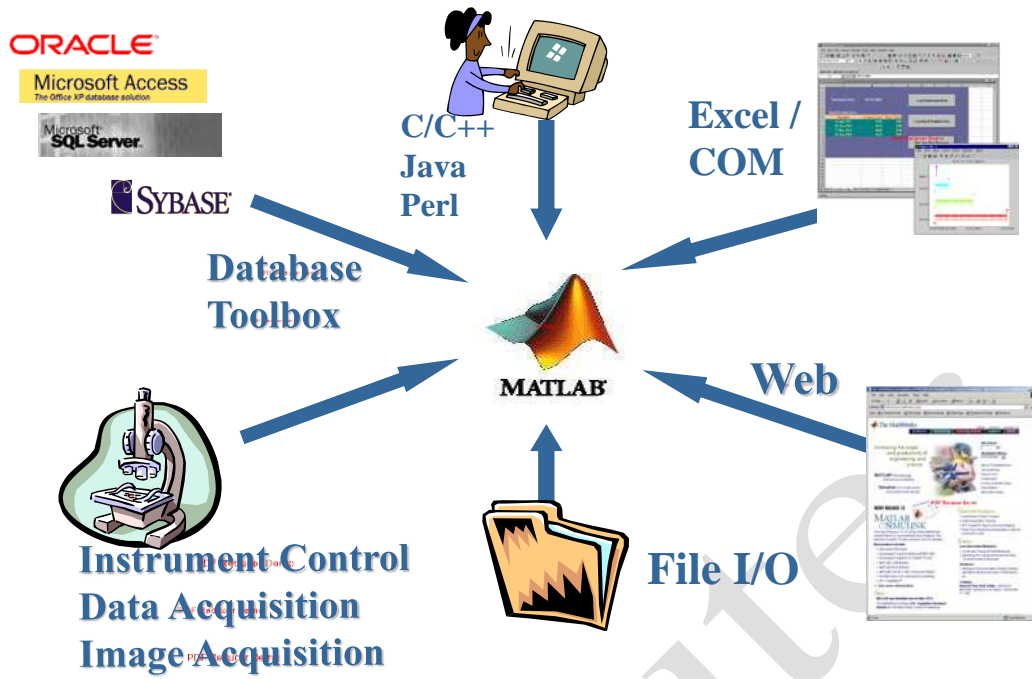

Deploying with MATLAB

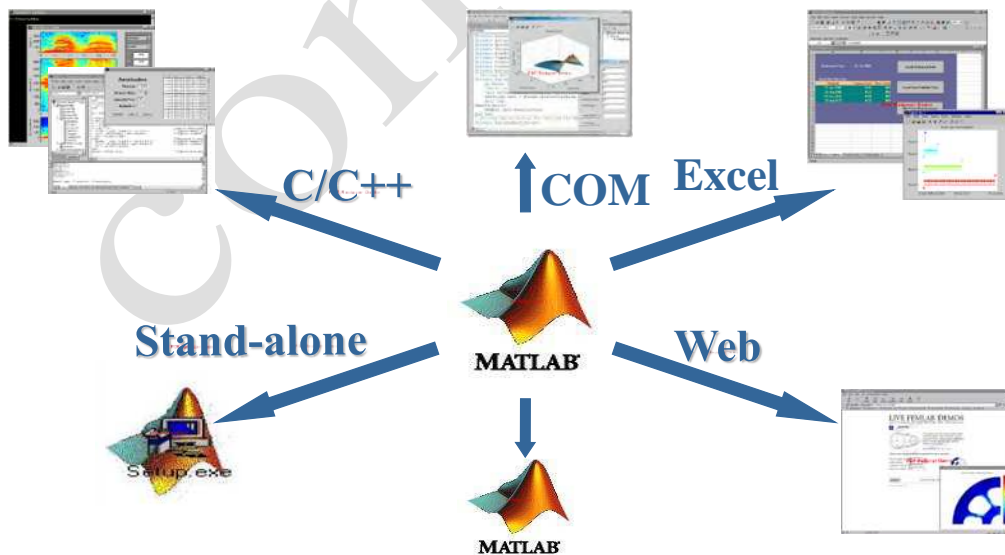

MATLAB

- The MATLAB environment is command oriented somewhat like UNIX.
- A prompt appears on the screen and a MATLAB statement can be entered.
- When the <ENTER> key is pressed, the statement is executed, and another prompt appears.
- If a statement is terminated with a semicolon (;), no results will be displayed.
- Otherwise results will appear before the next prompt.

The MATLAB User Interface

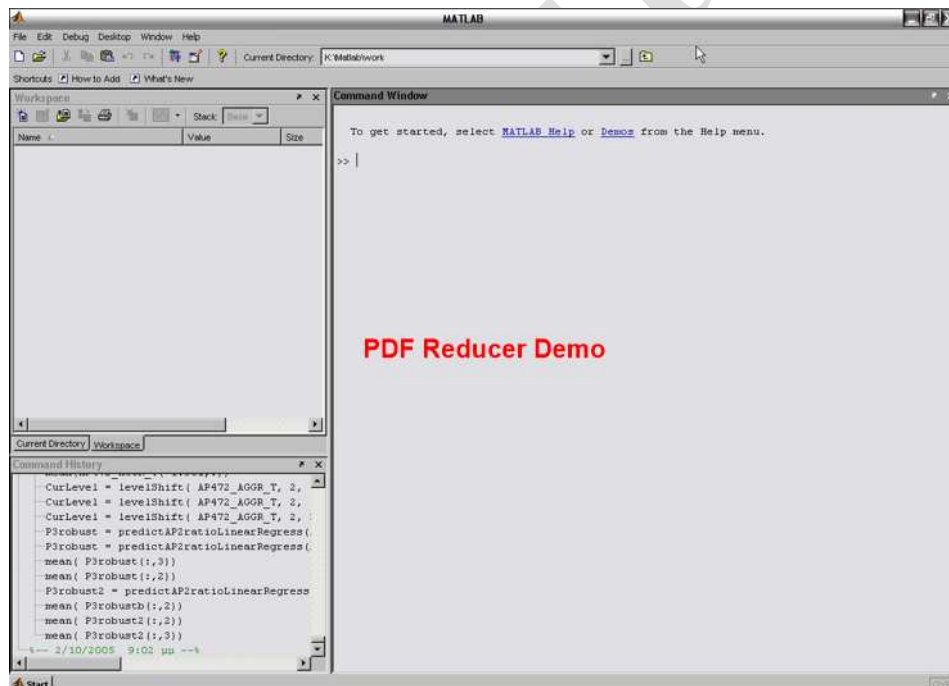

More about the Workspace

- who, whos – current variables in the workspace
- save – save workspace variables to *.mat file
- load – load variables from *.mat file
- clear – clear workspace variables

chapter two

**Everything in MATLAB is
a matrix!**

chapter two

Everything in MATLAB is a matrix!

Starting MATLAB

To get started, type one of these commands:

helpwin, helpdesk, or demo

» a=5;

» b=a/2

b =

2.5000

»

Variables

- No need for types. i.e.,

~~int a;
double b;
float c;~~

- All variables are created with double precision unless specified and they are matrices.

Example:

```
>>x=5;
```

```
>>x1=2;
```

- After these statements, the variables are 1x1 matrices with double precision

MATLAB Variable Names

- Variable names ARE case sensitive
- Variable names can contain up to 63 characters (as of MATLAB 6.5 and newer)
- Variable names must start with a letter followed by letters, digits, and underscores.

MATLAB Special Variables

1. ans Default variable name for results
2. pi Value of π
3. eps Smallest incremental number
4. inf Infinity
5. NaN Not a number e.g. 0/0
6. i and j $i = j = \text{square root of } -1$
7. realmin The smallest usable positive real number
8. realmax The largest usable positive real number

Different format

```
>> e=1/3
```

```
e =
```

```
0.3333 %default
```

```
>> format long
```

```
>> e
```

```
e =
```

```
0.3333333333333333 %long decimal
```

```
>> format short e
```

```
>> e
```

```
e =
```

```
3.3333e-001 %long exponential
```

To clear a variable

» who

Your variables are:

D ans rho

NRe mu v

» clear D

» who

Your variables are:

NRe ans mu rho v

»

Complex Numbers

Complex number i or j stands for $\sqrt{-1}$

» i

ans =

0 + 1.0000i

» c1 = 2+3i

c1 =

2.0000 + 3.0000i

»

Some functions deal with complex number

>> c=1-2i

c = 1.0000 - 2.0000i

>> abs(c)

ans = 2.2361

>> real(c)

ans = 1

>> imag(c)

ans = -2

>> angle(c)

ans = -1.1071

Mathematical Functions

» x=sqrt(2)/2

x =

0.7071

» y=sin(x)

y =

0.6496

»

Built-in Functions

Trigonometric functions	sin, cos, tan, sin, acos, atan, sinh, cosh, tanh, asinh, acosh, atanh, csc, sec, cot, acsc, ...
Exponential functions	exp, log, log10, sqrt
Complex functions	abs, angle, imag, real, conj
Rounding and Remainder functions	floor, ceil, round, mod, rem, sign

Math & Assignment Operators

Power ^ or .^ a^b or a.^b

Multiplication * or .* a*b or a.*b

Division / or ./ a/b or a./b

or \ or .\ b\a or b.\a

- (unary) + (unary)

Addition + a + b

Subtraction - a - b

Assignment = a = b (assign b to a)

Other MATLAB symbols

>> prompt

... continue statement on next line

, separate statements and data

% start comment which ends at end of line

;(1) suppress output

(2) used as a row separator in a matrix

: specify range

MATLAB Relational Operators

- MATLAB supports six relational operators.

Less Than <

Less Than or Equal <=

Greater Than >

Greater Than or Equal >=

Equal To ==

Not Equal To ~=

MATLAB Logical Operators

- MATLAB supports three logical operators.

not ~ % highest precedence

and & % equal precedence with or

or | % equal precedence with and

Exercise

Q1/

1) $8+3*5$
ans =23

2) $(8+3)*5$
ans =55

3) $4^2-12-8/4*2$
ans =0

4) $4^2 -12-8/(4*2)$
ans =3

5) $(3*4)^2+5$
ans =149

6) $27^{(1/3)}+32^{(0.2)}$
ans =5

7) $27^{1/3}+32^{0.2}$
ans =11

Q2/ use Matlab to computer the following expenssions:

a) $6\left(\frac{10}{13}\right) + \frac{18}{5(7)} + 5(9^2)$ sol (a)

ans = 410.1297

$6 * (10/13) + 18 / (5 * 7) + 5 * (9^2)$

ans = 410.1297

b) $6(35^{1/4}) + 14^{0.35}$ sol (b)

ans = 17.1123

$6 * 35^{(1/4)} + 14^{0.35}$

ans = 17.1123

c) $\frac{1}{2 + 3^2} + \frac{4}{5} * \frac{6}{7}$ Sol(c) $1 / (2+3^2) +$

ans = 0.7766

$4/5 * 6/7$

d) $\frac{1}{2} + 3^2 + \frac{4}{5} * \frac{6}{7}$ sol (d) $\frac{1}{2} + 3^2 +$

ans = 10.1857

$2 + 4/5 + 6/7$

e) sol(e)

$c = e^{-a} \sin(x) + 10\sqrt{y}$

for, $a = 5, x = 2, y = 8$

ans = 28.2904

$a = 5; x = 2; y = 8;$

$c = \exp(-a) * \sin(x) + 10 * \text{sqrt}(y)$

ans = 28.2904

$$f) \log (142)$$

$$\text{sol (f) } \log_{10} (142)$$

$$\text{Ans}=4.9558$$

Q3/ consider the equation:

$$1) f = \frac{\log(ax^2 + bx + c) - \sin(ax^2 + bx + c)}{4\pi x^2 + \cos(x - 2) * (ax^2 + bx + c)}$$

$$x=9;$$

$$a=1;$$

$$b=3$$

$$c=5;$$

$$\text{Poly} = a * x^2 + b * x + c;$$

$$\text{denom} = 4 * \pi * x^2 + \cos(x - 2) * \text{poly};$$

$$f = (\log(\text{poly}) - \sin(\text{poly})) / \text{denom}$$

$$F=0.0044$$

$$\text{Poly} = 113$$

$$\text{Denom} = 1.1031 e^{+03}$$

$$2) a = \frac{10 + 4x * 9/5 - \sin(b) + \tan(b^2)}{5 + 10b + 2\pi \log_{10} b}$$

$$\text{Where } b=5;$$

So

$$a = (10 + 4 * x * (9/5) - \sin(b) + \tan(b^2)) / (5 + 1 * b + 2 * \pi * \log_{10}(b))$$

$$\text{Ans}=0.3035$$

$$3) a = \frac{5 + 6 * 7 / 3 - \sin(2^2)}{2 / 3 * 3 / 3 * \cos(0.5)}$$

$$\text{Ans} = 33.7691$$

$$\text{Sol/ } a = (5 + 6 * (7 / 3) - \sin(2 \wedge 2)) / ((2 / 3) * (3 / 3) * \cos(0.5))$$

$$4) a = 2^3 + \frac{4 + \cos(x + y)}{5 + 3x + 2\pi \log_{10}(x + y)}$$

$$\text{Where: } x=2; y=5;$$

Sol/

$$a = 2 \wedge 3 + (4 + \cos(x + y)) / (5 + (3 * x) + 2 * \pi * \log_{10}(x + y))$$

$$\text{Ans} = 9.2915$$

MATLAB Matrices

- MATLAB treats all variables as matrices. For our purposes a matrix can be thought of as an array, in fact, that is how it is stored.
- Vectors are special forms of matrices and contain only one row OR one column.
- Scalars are matrices with only one row AND one column

MATLAB Matrices

- A matrix with only one row AND one column is a scalar. A scalar can be created in MATLAB as follows:

```
» x=23
```

```
x =
```

```
23
```

- A matrix with only one row is called a row vector. A row vector can be created in MATLAB as follows (note the commas):

```
» rowvec = [12 , 14 , 63]
```

```
rowvec =
```

```
12 14 63
```

- A matrix with only one column is called a column vector. A column vector can be created in MATLAB as follows (note the semicolons):

```
» colvec = [13 ; 45 ; -2]
```

```
colvec =
```

```
13
```

```
45
```

```
-2
```

- A matrix can be created in MATLAB as follows (note the commas AND semicolons):

» a = [1 , 2 , 3 ; 4 , 5 ,6 ; 7 , 8 , 9] Or

» a = [1 2 3 ; 4 5 6 ; 7 8 9] Or

```
>> a=[1 2 3
      4 5 6
      7 8 9]
```

a =

```
1 2 3
```

```
4 5 6
```

```
7 8 9
```

Extracting a Sub-Matrix

- A portion of a matrix can be extracted and stored in a smaller matrix by specifying the names of both matrices and the rows and columns to extract. The syntax is:

```
sub_matrix = matrix ( r1 : r2 , c1 : c2 ) ;
```

where r1 and r2 specify the beginning and ending rows and c1 and c2 specify the beginning and ending columns to be extracted to make the new matrix.

MATLAB Matrices

<ul style="list-style-type: none"> A column vector can be extracted from a matrix. As an example we create a matrix below: <code>» matrix=[1,2,3;4,5,6;7,8,9]</code> matrix = 1 2 3 4 5 6 7 8 9 	<ul style="list-style-type: none"> Here we extract column 2 of the matrix and make a column vector: <code>» coltwo=matrix(: , 2)</code> coltwo = 2 5 8
<ul style="list-style-type: none"> A row vector can be extracted from a matrix. As an example we create a matrix below: <code>» matrix=[1,2,3;4,5,6;7,8,9]</code> matrix = 1 2 3 4 5 6 7 8 9 	<ul style="list-style-type: none"> Here we extract row 2 of the matrix and make a row vector. Note that the 2:2 specifies the second row and the 1:3 specifies which columns of the row. <code>» rowvec=matrix(2 : 2 , 1 : 3)</code> rowvec = 4 5 6

Special Matrices

$$\text{eye}(3) = \begin{bmatrix} 1 & 0 & 0 \\ 0 & 1 & 0 \\ 0 & 0 & 1 \end{bmatrix} \quad \text{zeros}(3,2) = \begin{bmatrix} 0 & 0 \\ 0 & 0 \\ 0 & 0 \end{bmatrix}$$

$$\text{ones}(3) = \begin{bmatrix} 1 & 1 & 1 \\ 1 & 1 & 1 \\ 1 & 1 & 1 \end{bmatrix} \quad \text{ones}(2,4) = \begin{bmatrix} 1 & 1 & 1 & 1 \\ 1 & 1 & 1 & 1 \end{bmatrix}$$

Special Matrices functions

```
>> a=magic(4) %magic matrix
```

```
a =  
16  2  3 13  
 5 11 10  8  
 9  7  6 12  
 4 14 15  1
```

```
>> b=rand(5) %random matrix
```

```
b =  
0.8147 0.0975 0.1576 0.1419 0.6557  
0.9058 0.2785 0.9706 0.4218 0.0357  
0.1270 0.5469 0.9572 0.9157 0.8491  
0.9134 0.9575 0.4854 0.7922 0.9340  
0.6324 0.9649 0.8003 0.9595 0.6787
```

Some matrix building functions

```
>> a
```

```
a =
```

```
1  2  3  
4  5  6  
7  8  9
```

```
>> diag(a)
```

```
ans =
```

```
1  
5  
9
```

```
>> triu(a)
```

```
ans =
```

```
1  2  3  
0  5  6  
0  0  9
```

```
>> tril(a)
```

```
ans =
```

```
1  0  0  
4  5  0  
7  8  9
```

Concatenation of Matrices

- $x = [1 \ 2], y = [4 \ 5]$

$$A = [x \ y]$$

1 2 4 5

$$B = [x ; y]$$

1 2

4 5

Matrices Operations

Given A and B:

```
>> A = [1 2 3;4 5 6;7 8 9]
A =
     1     2     3
     4     5     6
     7     8     9
```

```
>> B = [3 5 2; 5 2 8; 3 6 9]
B =
     3     5     2
     5     2     8
     3     6     9
```

Addition

Subtraction

Product

Transpose

```
>> X = A + B
X =
     4     7     5
     9     7    14
    10    14    18
```

```
>> Y = A - B
Y =
    -2    -3     1
    -1     3    -2
     4     2     0
```

```
>> Z = A * B
Z =
    22    27    45
    55    66   102
    88   105   159
```

```
>> T = A'
T =
     1     4     7
     2     5     8
     3     6     9
```

Scalar - Matrix Addition

» a=3;

» b=[1, 2, 3;4, 5, 6]

b =

1 2 3

4 5 6

» c= b+a % Add a to each element of b

c =

4 5 6

7 8 9

Scalar - Matrix Subtraction

» a=3;

» b=[1, 2, 3;4, 5, 6]

b =

1 2 3

4 5 6

» c = b - a %Subtract a from each element of b

c =

-2 -1 0

1 2 3

Scalar - Matrix Multiplication

» a=3;

» b=[1, 2, 3; 4, 5, 6]

b =

1 2 3

4 5 6

» c = a * b % Multiply each element of b by a

c =

```
3 6 9
12 15 18
```

Scalar - Matrix Division

» a=3;

» b=[1, 2, 3; 4, 5, 6]

b =

```
1 2 3
4 5 6
```

» c = b / a % Divide each element of b by a

c =

```
0.3333  0.6667  1.0000
1.3333  1.6667  2.0000
```

The use of “.” – “Element” Operation

Given A:

A =		
3	5	3
6	8	2
2	7	3

Divide each
element of A by 2

```
>> A./2
ans =
1.5000  2.5000  1.5000
3.0000  4.0000  1.0000
1.0000  3.5000  1.5000
```

Multiply each
element of A by 3

```
>> A.*3
ans =
9  15  9
18 24  6
6  21  9
```

Square each element
of A

```
>> A.^2
ans =
9  25  9
36 64  4
4  49  9
```

Mean and Median

Mean: Average or mean value of a distribution

Median: Middle value of a sorted distribution

$M = \text{mean}(A), \quad M = \text{median}(A)$

$M = \text{mean}(A, \text{dim}), \quad M = \text{median}(A, \text{dim})$

$M = \text{mean}(A), M = \text{median}(A)$: Returns the mean or median value of vector A.

If A is a multidimensional mean/median returns an array of mean values.

Example:

$A = [0 \ 2 \ 5 \ 7 \ 20]$

$B = [1 \ 2 \ 3$

$3 \ 3 \ 6$

$4 \ 6 \ 8$

$4 \ 7 \ 7]$;

$\text{mean}(A) = 6.8$

$\text{mean}(B) = 3.0000 \ 4.5000 \ 6.0000$ (column-wise mean)

$\text{mean}(B,2) = 2.0000 \ 4.0000 \ 6.0000 \ 6.0000$ (row-wise mean)

Examples:

$A = [0 \ 2 \ 5 \ 7 \ 20]$

$B = [1 \ 2 \ 3$

$3 \ 3 \ 6$

$4 \ 6 \ 8$

$4 \ 7 \ 7]$;

Mean:

$\text{mean}(A) = 6.8$

$\text{mean}(B) = 3.0 \ 4.5 \ 6.0$ (column-wise mean)

$\text{mean}(B,2) = 2.0 \ 4.0 \ 6.0 \ 6.0$ (row-wise mean)

Median:

$\text{median}(A) = 5$

$\text{median}(B) = 3.5 \ 4.5 \ 6.5$ (column-wise median)

median(B,2) = 2.0

3.0

6.0

7.0 (row-wise median)

Standard Deviation and Variance

- Standard deviation is calculated using the std() function
- std(X) : Calculate the standard deviation of vector x
- If x is a matrix, std() will return the standard deviation of each column
- Variance (defined as the square of the standard deviation) is calculated using the var() function
- var(X) : Calculate the variance of vector x
- If x is a matrix, var() will return the standard deviation of each column

X = [1 5 9;7 15 22]

s = std(X)

s = 4.2426 7.0711 9.1924

Insert element to matrix

» B=[1 3 7 8;2 6 5 11;12 14 15 13]

B =

1 3 7 8

2 6 5 11

12 14 15 13

To insert element 42 to row 2 and column 5

» B(2,5)= 42

B =

م.د. رنا بهجت اسماعيل، م. عادل عبد الكاظم و م.م. ايمان احمد قسم الرياضيات /المرحلة الثانية

```
1  3  7  8  0
2  6  5 11 42
12 14 15 13 0
```

» B=[1 3 7 8;2 6 5 11;12 14 15 13]

B =

```
1  3  7  8
2  6  5 11
12 14 15 13
```

To insert elements 11,13,54,31 to row 4 and columns 1,2,3,4

» B(4,1:4)= [31 54 13 11]

B =

```
1  3  7  8
2  6  5 11
12 14 15 13
31 54 13 11
```

Replace element in a matrix

» B=[1 3 7 8;2 6 5 11;12 14 15 13]

B =

```
1  3  7  8
2  6  5 11
12 14 15 13
```

To replace element in row 3 and column 1 by number 0

» B(3,1)= 0

B =

م.د. رنا بهجت اسماعيل، م. عادل عبد الكاظم و م.م. ايمان احمد قسم الرياضيات /المرحلة الثانية

```
1 3 7 8
2 6 5 11
0 14 15 13
```

» B=[1 3 7 8;2 6 5 11;12 14 15 13]

B =

```
1 3 7 8
2 6 5 11
12 14 15 13
```

To replace many elements in row 1,2 and columns 1,2,3 by number 0

» B(1:2,1:3)= 0

B =

```
0 0 0 8
0 0 0 11
12 14 15 13
```

Delete elements in a matrix

In Matlab , you can delete row or column in a matrix

» B=[1 3 7 8;2 6 5 11;12 14 15 13]

B =

```
1 3 7 8
2 6 5 11
12 14 15 13
```

To delete row 3

» B(3,:) = []

B =

```
1 3 7 8
2 6 5 11
```

To delete column 4

» $B(:,4) = []$

B =

1 3 7

2 6 5

12 14 15

Find elements in a matrix

To find element in row 1 and column 3 in matrix B

» $B(1,3)$

ans =

7

To find elements in row 2 and columns from 2 to 4

» $B(2,2:4)$

ans =

6 5 11

To find last element in a row or column

» $B(2,end) =$

ans =

11

Equality of Matrices

- Equality of matrices: Matrices A, B are said to be equal if A and B have the same size and corresponding elements are equal; i.e., A and B have dimension $m \times n$, and $A = [a_{ij}]$, $B = [b_{ij}]$, with $a_{ij} = b_{ij}$, $1 \leq i \leq m$, $1 \leq j \leq n$.

Matrix Addition

- Addition of matrices: Let $A = [a_{ij}]$ and $B = [b_{ij}]$ be of the same size.

Then

$$A + B = [a_{ij}] + [b_{ij}] = [a_{ij} + b_{ij}]$$

is the matrix obtained by adding corresponding elements of A and B.

Scalar Multiple of a Matrix

- Scalar multiple of a matrix: Let $A = [a_{ij}]$ and t be a number (scalar).

Then tA is the matrix obtained by multiplying all elements of A by t ;

that is

$$tA = t[a_{ij}] = [ta_{ij}]$$

Negative of a Matrix

- Negative of a matrix: Let $A[a_{ij}]$. Then $-A$ is the matrix obtained by replacing the elements of A by their negatives; that is

$$-A = -[a_{ij}] = [-a_{ij}]$$

Matrix Subtraction

- Subtraction of matrices: Matrix subtraction is defined for two matrices $A[a_{ij}]$ and $B[b_{ij}]$ of the same size, in the usual way; that is

$$A - B = [a_{ij}] - [b_{ij}] = [a_{ij} - b_{ij}]$$

Matrix Operations

- The matrix operations of addition, scalar multiplication, negation and subtraction satisfy the usual laws of arithmetic.
- s, t are scalars and A, B, C are matrices of the same size.

1. $(A+B)+C=A+(B+C)$;
2. $A+B=B+A$;
3. $0+A=A$;
4. $A+(-A) = 0$;
5. $(s+t)A=sA+tA, (s-t)A=sA-tA$;
6. $t(A+B) = tA+tB, t(A-B) = tA-tB$;

Matrix Multiplication

$$8. 1A = A, 0A = 0, (-1)A = -A;$$

$$9. tA = 0 \Rightarrow t = 0 \text{ or } A = 0$$

(Matrix product) Let $A = [a_{ij}]$ be a matrix of size $m \times p$ and $B = [b_{jk}]$ be a matrix of size $p \times n$; (that is the number of columns of A equals the number of rows of B). Then AB is the $m \times n$ matrix $C = [c_{ik}]$ whose (i, j) -th element is defined by the formula

$$c_{ij} = \sum_{k=1}^p a_{ik}b_{kj} = a_{i1}b_{1j} + \dots + a_{ip}b_{pj}$$

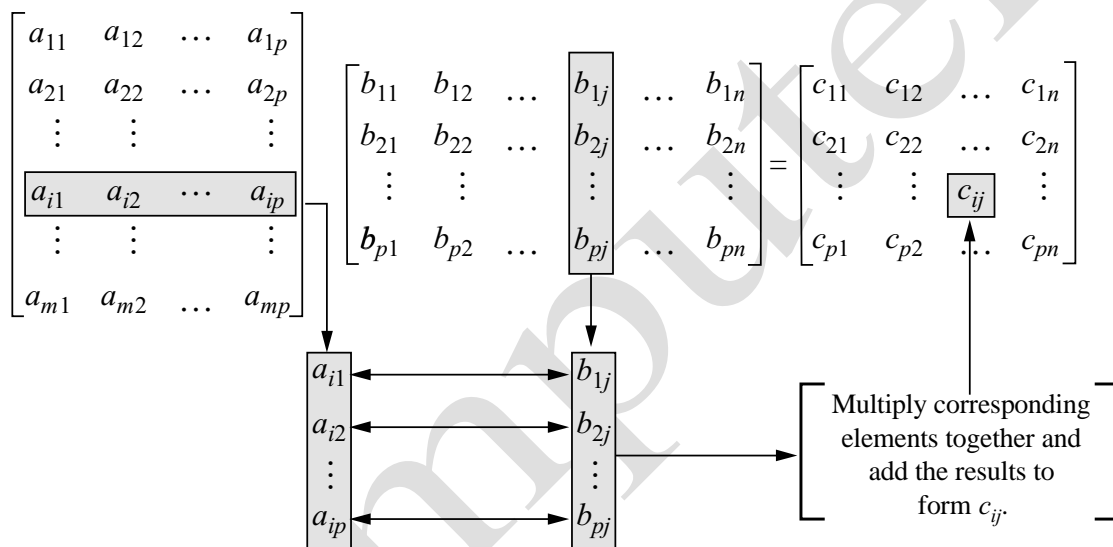

Examples of Matrix Multiplication

$$\begin{bmatrix} 1 & 2 \\ 3 & 4 \end{bmatrix} \begin{bmatrix} 5 & 6 \\ 7 & 8 \end{bmatrix} = \begin{bmatrix} 1 \times 5 + 2 \times 7 & 1 \times 6 + 2 \times 8 \\ 3 \times 5 + 4 \times 7 & 3 \times 6 + 4 \times 8 \end{bmatrix} = \begin{bmatrix} 19 & 22 \\ 43 & 50 \end{bmatrix}$$

$$\begin{bmatrix} 5 & 6 \\ 7 & 8 \end{bmatrix} \begin{bmatrix} 1 & 2 \\ 3 & 4 \end{bmatrix} = \begin{bmatrix} 23 & 34 \\ 31 & 46 \end{bmatrix} \neq \begin{bmatrix} 1 & 2 \\ 3 & 4 \end{bmatrix} \begin{bmatrix} 5 & 6 \\ 7 & 8 \end{bmatrix}$$

$$\begin{bmatrix} 1 \\ 2 \end{bmatrix} \begin{bmatrix} 3 & 4 \end{bmatrix} = \begin{bmatrix} 3 & 4 \\ 6 & 8 \end{bmatrix}$$

$$\begin{bmatrix} 3 & 4 \end{bmatrix} \begin{bmatrix} 1 \\ 2 \end{bmatrix} = \begin{bmatrix} 11 \end{bmatrix}$$

$$\begin{bmatrix} 1 & -1 \\ 1 & -1 \end{bmatrix} \begin{bmatrix} 1 & -1 \\ 1 & -1 \end{bmatrix} = \begin{bmatrix} 0 & 0 \\ 0 & 0 \end{bmatrix}$$

Laws of Matrix Multiplication

Matrix multiplication obeys many of the familiar laws of arithmetic apart from the commutative law.

1. $(AB)C = A(BC)$ if A, B, C are $m \times n, n \times p, p \times q$, respectively;
2. $t(AB) = (tA)B = A(tB), A(-B) = (-A)B = -(AB)$;
3. $(A+B)C = AC + BC$ if A and B are $m \times n$ and C is $n \times p$;
4. $D(A+B) = DA + DB$ if A and B are $m \times n$ and D is $p \times m$.

System of Linear Equations

- System of m linear equations in n unknowns:

$$\begin{aligned} a_{11}x_1 + a_{12}x_2 + \cdots + a_{1n}x_n &= b_1 \\ a_{21}x_1 + a_{22}x_2 + \cdots + a_{2n}x_n &= b_2 \\ &\vdots \\ a_{m1}x_1 + a_{m2}x_2 + \cdots + a_{mn}x_n &= b_m \end{aligned}$$

- Equivalent matrix equation $Ax=b$.

$$\begin{bmatrix} a_{11} & a_{12} & \cdots & a_{1n} \\ a_{21} & a_{22} & \cdots & a_{2n} \\ \vdots & & & \vdots \\ a_{m1} & a_{m2} & \cdots & a_{mn} \end{bmatrix} \begin{bmatrix} x_1 \\ x_2 \\ \vdots \\ x_n \end{bmatrix} = \begin{bmatrix} b_1 \\ b_2 \\ \vdots \\ b_m \end{bmatrix}$$

- A is the coefficient matrix

- Vector or unknowns: $x = \begin{bmatrix} x_1 \\ x_2 \\ \vdots \\ x_n \end{bmatrix}$

- Vector of constants (right-hand side): $b = \begin{bmatrix} b_1 \\ b_2 \\ \vdots \\ b_m \end{bmatrix}$

Equivalent Equation for $Ax = b$

$$x_1 \begin{bmatrix} a_{11} \\ a_{21} \\ \vdots \\ a_{m1} \end{bmatrix} + x_2 \begin{bmatrix} a_{12} \\ a_{22} \\ \vdots \\ a_{m2} \end{bmatrix} + \cdots + x_n \begin{bmatrix} a_{1n} \\ a_{2n} \\ \vdots \\ a_{mn} \end{bmatrix} = \begin{bmatrix} b_1 \\ b_2 \\ \vdots \\ b_m \end{bmatrix}$$

Example of a Linear System

- System
$$\begin{aligned} x + y + z &= 1 \\ x - y + z &= 0 \\ 3x + 5y - z &= 2 \end{aligned}$$

- Matrix form
$$\begin{bmatrix} 1 & 1 & 1 \\ 1 & -1 & 1 \\ 3 & 5 & -1 \end{bmatrix} \begin{bmatrix} x \\ y \\ z \end{bmatrix} = \begin{bmatrix} 1 \\ 0 \\ 2 \end{bmatrix}$$

- Alternative form
$$x \begin{bmatrix} 1 \\ 1 \\ 3 \end{bmatrix} + y \begin{bmatrix} 1 \\ -1 \\ 5 \end{bmatrix} + z \begin{bmatrix} 1 \\ 1 \\ -1 \end{bmatrix} = \begin{bmatrix} 1 \\ 0 \\ 2 \end{bmatrix}$$

- Solution
$$\begin{bmatrix} 0.0000 \\ 0.5000 \\ 0.5000 \end{bmatrix}$$

$$(1) 0.0000 + (1) 0.5000 + (1) 0.5000 = 1$$

$$(1) 0.0000 - (1) 0.5000 + (1) 0.5000 = 0$$

$$3(0.0000) + 5(0.5000) - (1) 0.5000 = 2$$

The Trace

If A is an $n \times n$ matrix, the trace of A , written $\text{trace}(A)$, is the sum of the diagonal elements; that is

$$\text{trace}(A) = a_{11} + a_{22} + \cdots + a_{nn} = \sum_{i=1}^n a_{ii}.$$

Example of the Trace

If $A = \begin{bmatrix} 5 & 8 & 12 & -1 \\ 7 & 4 & -8 & 7 \\ 0 & 3 & -6 & 5 \\ -1 & -9 & 4 & 3 \end{bmatrix}$, then $\text{trace}(A) = 5 + 4 + (-6) + 3 = 6$.

Properties of the Trace

- $\text{trace}(A + B) = \text{trace}(A) + \text{trace}(B)$
- $\text{trace}(cA) = c \text{trace}(A)$, where c is a scalar.
- If A is an $n \times n$ matrix and B is an $n \times n$ matrix, then $\text{trace}(AB) = \text{trace}(BA)$.

MATLAB

- When performing vector or matrix operations using the operators '*', '/', and '^', it may be necessary to use the dot operator ('.') to perform element by element operations.

MATLAB Examples

```
>> A = [1 5 1;2 -1 6;1 0 3]
A =
     1     5     1
     2    -1     6
     1     0     3
>> B = [2 3 0;3 -1 7;4 8 9]
B =
     2     3     0
     3    -1     7
     4     8     9
>> 5*A -10*B + 3*A*B
ans =
    48    13   137
    55   170   101
     7     1     6
>> trace(A + B)
ans =
    13
>> 7*trace(A + B)
ans =
    91
>> trace(A*B)
ans =
   103
>> trace(B*A)
ans =
   103
>> A.*B
ans =
     2    15     0
     6     1    42
     4     0    27
```

Another MATLAB Example

- It is a common mistake to forget using "." when dividing an expression into a constant.

```
>> v = [1 2 3 4 5]';
```

```
>> 1./v
```

```
ans =
```

```
1.0000
```

```
0.5000
```

```
0.3333
```

```
0.2500
```

```
0.2000
```

MATLAB Exponentiation Operator

- Operator '^'. When vectorization is used, you must use it in the form '^.'. For instance, if t is the vector

```
t = [1.0:0.5:3.0]
```

then

```
y = t.^2
```

is the vector whose elements are the squares of those in t.

```
>> t = [1.0:0.5:3.0]
```

```
t =
```

```
1.0000 1.5000 2.0000 2.5000 3.0000
```

```
>> y = t.^2
```

```
y =
```

```
1.0000 2.2500 4.0000 6.2500 9.0000
```

Powers of Matrices

- The $n \times n$ identity matrix has ones on its diagonal and zeros in all other locations.

$$I = \begin{bmatrix} 1 & & & & \\ & 1 & & & \\ & & \ddots & & \\ & & & 1 & \\ & & & & 1 \end{bmatrix}$$

- If A is an $n \times n$ matrix, $A * I = I * A = A$.

The Matrix Inverse

- An $n \times n$ matrix A is invertible, or nonsingular, if there exists an $n \times n$ matrix denoted by A^{-1} such that

$$A * A^{-1} = A^{-1} * A = I$$

- For example if $A = \begin{bmatrix} 1 & 0 & 2 \\ 1 & 3 & 0 \\ 2 & 1 & 5 \end{bmatrix}$, then

$$A^{-1} = \begin{bmatrix} 3 & \frac{2}{5} & -\frac{6}{5} \\ -1 & \frac{1}{5} & \frac{2}{5} \\ -1 & -\frac{1}{5} & \frac{3}{5} \end{bmatrix}$$

Properties of the Matrix Inverse

- A matrix A can have only one inverse.
- If B is a matrix such that $BA = I$, then $AB = I$. Similarly, if $AB = I$, then $BA = I$; in other words $B = A^{-1}$.
- $(AB)^{-1} = B^{-1} A^{-1}$
- $(B^{-1} A^{-1})(AB) = B^{-1}(A^{-1}A)B = B^{-1}(I)B = B^{-1}B = I$
- If the coefficient matrix, A, of an $n \times n$ linear system $Ax = b$ has an inverse then the unique solution to the system is

$$x = A^{-1}b$$

Computing the Inverse using MATLAB

- Use the command `inv`.

```
>> A = [6 15 -1;12 9 -8;-1 2 3]
```

```
A =
```

```
6 15 -1
12 9 -8
-1 2 3
```

```
>> B = inv(A)
```

```
B =
```

```
-0.220512820512820 0.241025641025641 0.569230769230769
0.143589743589744 -0.087179487179487 -0.184615384615385
-0.169230769230769 0.138461538461538 0.646153846153846
```

```
>> A*B
```

```
ans =
```

```
1.000000000000000 -0.000000000000000 0
0 1.000000000000000 0
0.000000000000000 -0.000000000000000 1.000000000000000
```

The Matrix Transpose

- If A is an $m \times n$ matrix, the transpose A^T is the $n \times m$ matrix obtained by exchanging rows and columns. If A is the matrix $[a_{ij}]$, then

$$(A^T)_{ij} = a_{ji}.$$

$$\begin{bmatrix} 1 & 3 & -1 & 7 \\ 2 & 5 & 8 & -9 \\ 4 & 0 & 1 & 12 \end{bmatrix}^T = \begin{bmatrix} 1 & 2 & 4 \\ 3 & 5 & 0 \\ -1 & 8 & 1 \\ 7 & -9 & 12 \end{bmatrix}$$

Properties of the Transpose

1. $(A^T)^T = A$;
2. $(A \pm B)^T = A^T \pm B^T$ if A and B are $m \times n$;
3. $(sA)^T = sA^T$ if s is a scalar;
4. $(AB)^T = B^T A^T$ if A is $m \times k$ and B is $k \times n$;
5. A is nonsingular, then A^T is also nonsingular and $(A^T)^{-1} = (A^{-1})^T$.
6. $x^T x = x_1^2 + \dots + x_n^2$ if $x = [x_1, \dots, x_n]^T$ is a column vector.

A Symmetric Matrix

- An $n \times n$ matrix A is symmetric if $A^T = A$

$$A = \begin{bmatrix} 1 & 8 & 12 & 3 \\ 8 & 5 & 1 & 10 \\ 12 & 1 & 6 & 9 \\ 3 & 10 & 9 & 2 \end{bmatrix} = A^T$$

- Symmetric matrices appear very frequently in engineering and science problems.
- Computations with symmetric matrices can normally be done faster than with nonsymmetric matrices.

A Very Important Symmetric Matrix

- If A is an $m \times n$ matrix then $A^T A$ is an $n \times n$ matrix.
- A^T is $n \times m$, and an $(n \times m)$ times an $(m \times n)$ matrix has dimensions $n \times n$.
- If A is an $m \times n$ matrix, then $A^T A$ is an $n \times n$ symmetric matrix.

$$(A^T A)^T = A^T (A^T)^T = A^T A$$

The Transpose in MATLAB

- Use the operator $A = [1 \ 8 \ -1; 3 \ -9 \ 15; -1 \ 5 \ 3]$

```
A =  
     1     8    -1  
     3    -9    15  
    -1     5     3
```

```
>> A_TA = A'*A
```

```
A_TA =  
     11    -24     41  
    -24    170    -128  
     41   -128    235
```

```
>> A_TA - A_TA'
```

```
ans =  
     0     0     0  
     0     0     0  
     0     0     0
```

Chapter three

M-Files

Chapter three

M-Files

- **Script file:** a collection of MATLAB commands
- **Function file:** a definition file for one function

Script Files

- Any valid sequence of MATLAB commands can be in the script files.
- Variables defined/used in script files are global, i.e., they present in the workspace.

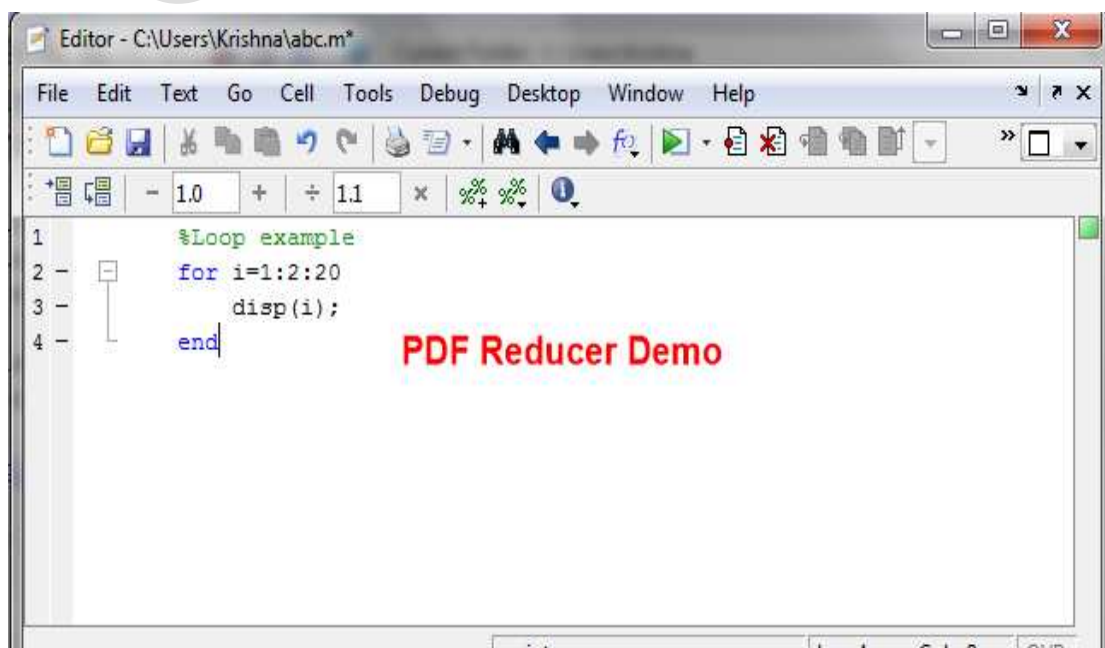
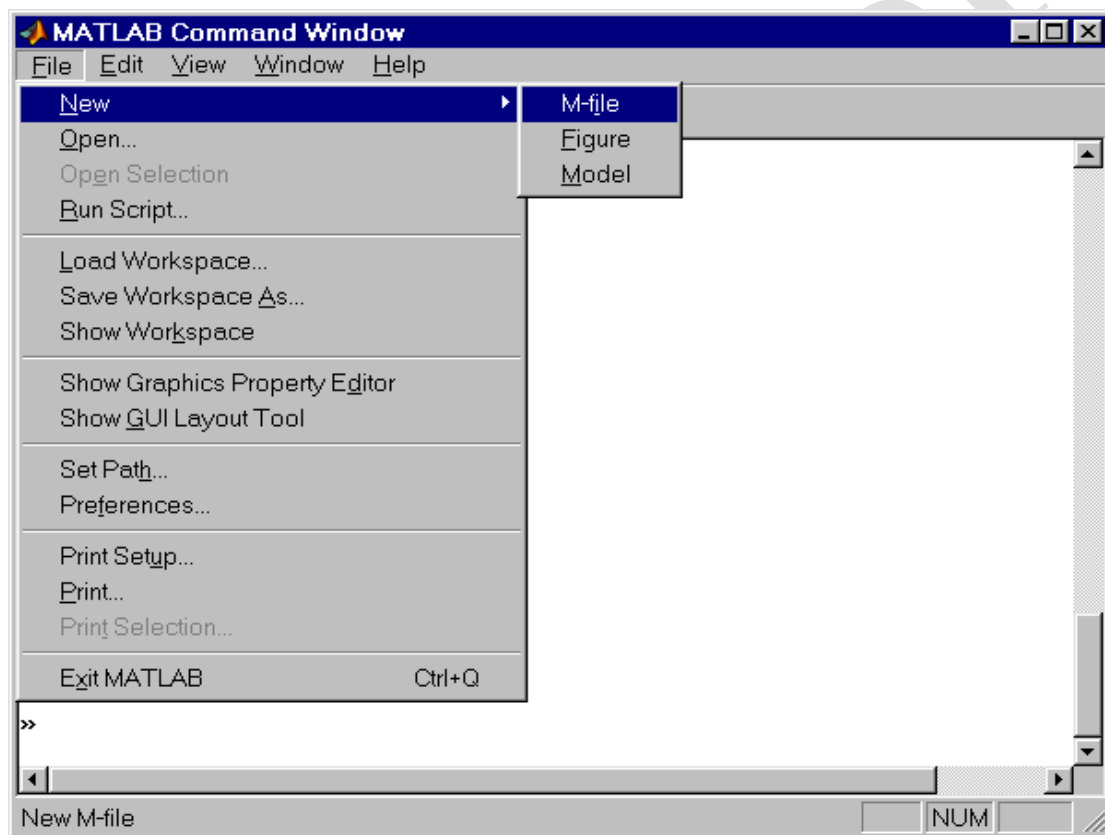

M-file Example

%test.m

```
A=[1 2 3;4 5 6;7 8 9]
B=sum(sum(A))
C=prod(sum(A))
```

%output

```
>> test
A=
     1     2     3
     4     5     6
     7     8     9
B=
    45
C=
   3240
```

%test.m

```
A=[11 22 33;41 51 61;78 88 98]
B=sum(sum(A))
C=prod(sum(A))
```

%output

```
>> test
A=
    11    22    33
    41    51    61
    78    88    98
B=
   483
C=
  4018560
```

%test.m

```
clc
A=[1 2 3 ;4 5 6 ;7 8 9]
B=sum(sum(A))
C=prod(sum(A))
```

%output

```
>> test
A=
     1     2     3
     4     5     6
     7     8     9
B=
    45
C=
   3240
```

%test.m

```
clc
A=[11 21 31 ;42 52 62 ;73 38 39]
B=sum(sum(A))
C=prod(sum(A))
```

%output

```
>> test
A=
    11    21    31
    42    52    62
    73    38    39
B=
    369
C=
    1846152
```

%test.m

```
clc
A=[1 2 3 ;4 5 6 ;7 8 9]
B=sum(sum(A))
C=prod(sum(A))
```

%output

```
>> test
A=
     1     2     3
     4     5     6
     7     8     9
B=
    45
C=
   3240
```

%test.m

```
clc
D=[1 2 3 ;4 5 6 ;7 8 9]
E=sum(sum(D))
F=prod(sum(D))
```

%output

```
>> test
D=
     1     2     3
     4     5     6
     7     8     9
E=
    45
F=
   3240
```

%test.m

```
clc
clear
D=[1 2 3;4 5 6;7 8 9]
E=sum(sum(D))
F=prod(sum(D))
```

%output

```
>> test
D=
     1     2     3
     4     5     6
     7     8     9
E=
    45
F=
   3240
```

%example.m

```
A=[3 4 9;2 4 5]
B=size (A)
C= size(A,1)
D = size(A,2)
```

%output

```
>> example
A=
     3     4     9
     2     4     5
B=
     2     3
C=
     2
D=
     3
```

%example.m

```
A=[1 15 2 11;23 1 4 5;3 1 15 7;1 4 9 10]
B=max(A)
C=max(B)
```

%output

```
>> example
A=
     1    15     2    11
    23     1     4     5
     3     1    15     7
     1     4     9    10
B=
    23    15    15
11
C=
    23
```

```
%example.m
```

```
A=[1 15 2 11;23 1 4 5;3 1 15 7;1 4 9 10]  
B=min(A)  
C=min(B)
```

```
%output
```

```
>> example  
A=  
 1 15 2 11  
23 1 4 5  
 3 1 15 7  
 1 4 9 10  
B=  
 1 1 2 5  
C=  
 1
```

```
%example.m
```

```
A=[1 2 3 4 5 6 7 8 9 10]  
B= length(A)
```

```
%output
```

```
>> example  
A=  
 1 2 3 4 5 6 7 8 9 10  
B=  
 10
```

```
%example.m
```

```
A=[1 2 3;4 5 6;7 8 9]  
B= fliplr(A)
```

```
%output
```

```
>> example  
A=  
 1 2 3  
 4 5 6  
 7 8 9  
B=  
 3 2 1  
 6 5 4  
 9 8 7
```

%example.m

```
A=[1 2 3;4 5 6;7 8 9]
B= flipud(A)
```

%output

```
>> example
A=
    1  2  3
    4  5  6
    7  8  9
B=
    7  8  9
    4  5  6
    1  2  3
```

%example.m

```
A=[1 2 3;4 5 6;7 8 9]
B= rot90(A)
```

%output

```
>> example
A=
    1  2  3
    4  5  6
    7  8  9
B=
    3  6  9
    2  5  8
    1  4  7
```

%example.m

```
A=[1 2 3 ;4 5 6 ;7 8 9;10 11 12]
B= reshape(A,6,2)
```

%output

```
>> example
A=
    1  2  3
    4  5  6
    7  8  9
   10 11 12
B=
    1  8
    4 11
    7  3
   10  6
    2  9
    5 12
```

example.m

```
X = linspace(pi,-pi,8)
Y = sin(x)
```

%output

```
>> example
X = 3.14 2.24 1.35 0.45 -0.45 -1.35 -2.24 -3.14
Y = 0.00 0.78 0.97 0.43 -0.43 -0.97 -0.78 0.00
```

example.m

```
X = [ 7 5 2 1 3 6 4 8]
Y = sort(X)
```

%output

```
>> example
X = 7 5 2 1 3 6 4 8
Y = 1 2 3 4 5 6 7 8
```

Chapter four

MATLAB Graphics

Chapter four

MATLAB Graphics

- One of the best things about MATLAB is interactive graphics
- “plot” is the one you will be using most often

Plotting Commands

plot(independent variable, dependent variable)

plot(x,y) defaults to a blue line

plot(independent variable, dependent variable, 'property')

plot(x,y,'ro') uses red circles

plot(x,y,'g*') uses green asterisks

If you want to put two plots on the same graph, use “hold on”

plot(a,b,'r:') (red dotted line)

hold on

plot(a,c,'ko') (black circles)

Color, Symbols, and Line Types

Colors	Symbols	Line Types
b blue	. point	- solid
g green	o circle	: dotted
r red	x x-mark	-. dashdot
c cyan	+ plus	-- dashed
m magenta	* star	
y yellow	s square	
k black	d diamond	
	v triangle (down)	
	^ triangle (up)	
	< triangle (left)	
	> triangle (right)	
	p pentagram	

Example

```
clc
clear
x=0 : 0.1 : 10;
y= sin(x);
plot(x,y);
```

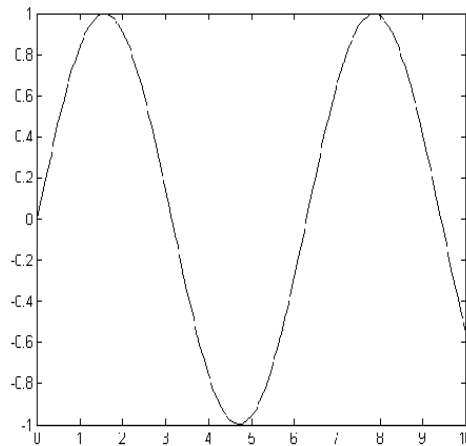

Plotting

PLOT Linear plot.

- PLOT(X,Y) plots vector Y versus vector X
- PLOT(X,Y,'S') with plot symbols and colors

Example

```
x = [-3 -2 -1 0 1 2 3];
y = (x.^2) -1;
plot(x, y, 'r');
```

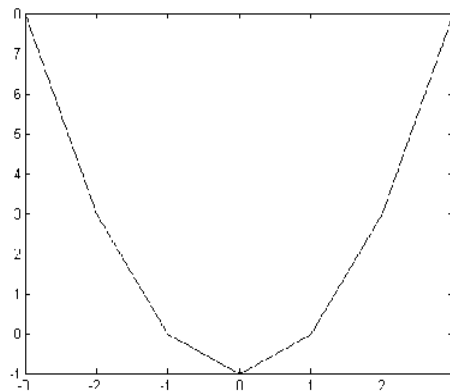

Plot Properties

XLABEL X-axis label.

- XLABEL('text') adds text beside the X-axis on the current axis.

YLABEL Y-axis label.

- YLABEL('text') adds text beside the Y-axis on the current axis.

Example

```
x = [-3 -2 -1 0 1 2 3];  
y = (x.^2) -1;  
plot(x, y, 'r');  
xlabel('x values');  
ylabel('y values');
```

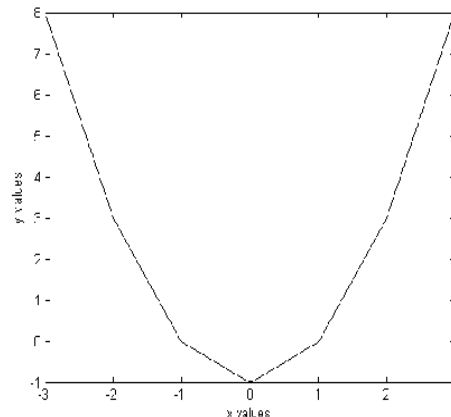

Hold

HOLD Hold current graph.

- HOLD ON holds the current plot and all axis properties so that subsequent graphing commands add to the existing graph.
- HOLD OFF returns to the default mode

Example

```
x = [-3 -2 -1 0 1 2 3];  
y = (x.^2) -1;  
plot(x, y, 'r');  
xlabel('x values');  
ylabel('y values');  
hold on;  
y1 = x + 2;  
plot(x, y1, 'g+');
```

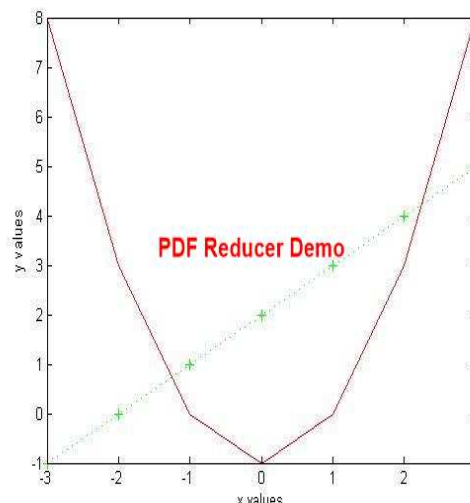

Subplot

SUBPLOT Create axes in tiled positions.

- SUBPLOT(m,n,p), or SUBPLOT(mnp), breaks the Figure window into an m-by-n matrix of small axes

Example

```
x = [-3 -2 -1 0 1 2 3];
y1 = (x.^2) -1;
% Plot y1 on the top
subplot(2,1,1);
plot(x, y1,'r-.');
xlabel('x values');
ylabel('y values');
% Plot y2 on the bottom
subplot(2,1,2);
y2 = x + 2;
plot(x, y2, 'm*-');
```

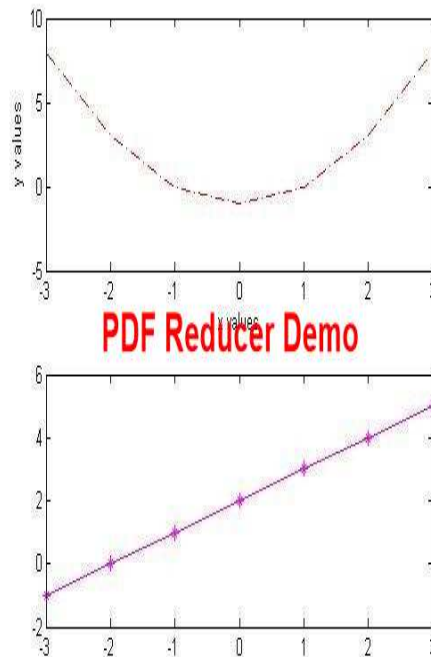

Figure

FIGURE Create figure window.

- **FIGURE**, by itself, creates a new figure window, and returns its handle.

Example

```
x = [-3 -2 -1 0 1 2 3];
y1 = (x.^2) -1;
% Plot y1 in the 1st Figure
plot(x, y1,'bo-');
xlabel('x values');
ylabel('y values');
% Plot y2 in the 2nd Figure
figure
plot(x, y2, 'm*-');
```

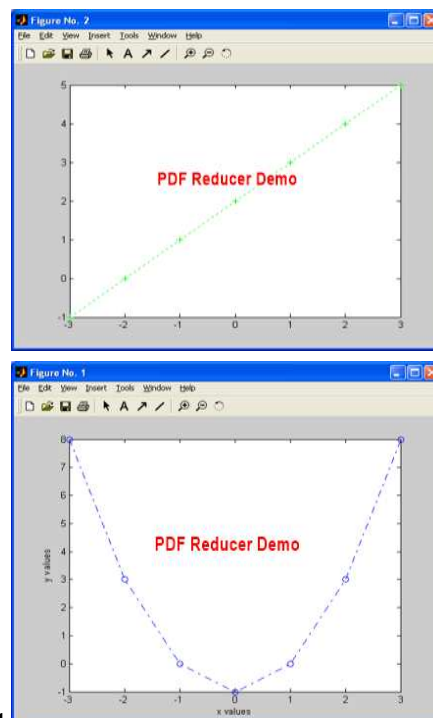

```
plot(x, y2, 'g+');
```

Surface Plot

```
x = 0:0.1:2;
```

```
y = 0:0.1:2;
```

```
[xx, yy] = meshgrid(x,y);
```

```
zz=sin(xx.^2+yy.^2);
```

```
surf(xx,yy,zz)
```

```
xlabel('X axes')
```

```
ylabel('Y axes')
```

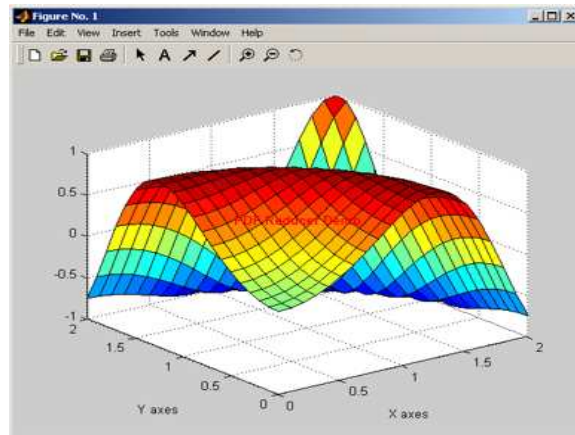

```
[X,Y] = meshgrid(-2:.2:2, -2:.2:2);
```

```
Z = X .* exp(-X.^2 - Y.^2);
```

```
surf(X,Y,Z)
```

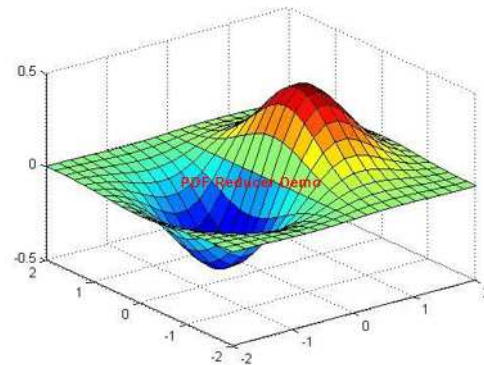

2D line plot

```
x=0:0.05:5;
```

```
y=sin(x.^2);
```

```
plot(x,y);
```

```
xlabel('time');
```

```
ylabel('amplitude');
```

```
grid;
```

```
title('The sine wave graph')
```

```
legend('x-y relation');
```

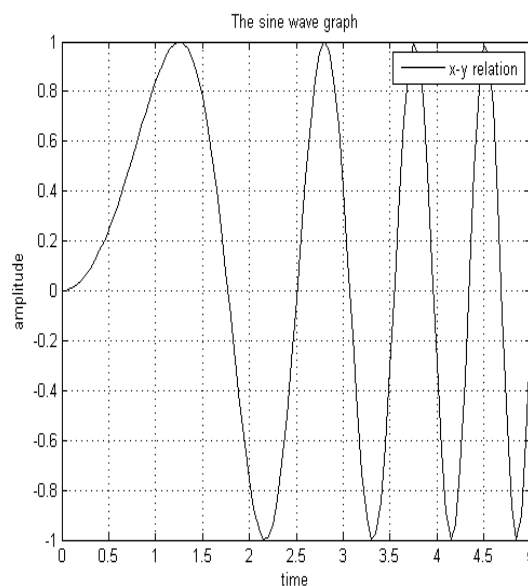

Bar plot

```
x= -2.9:0.2:2.9;  
bar(x,exp(-x.*x));
```

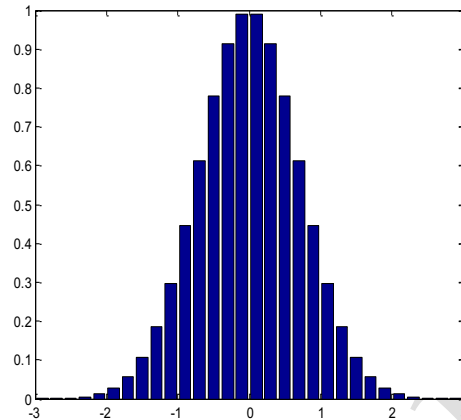

Stairstep plot of sine wave

```
x=0:0.25:10;  
stairs(x,sin(x));
```

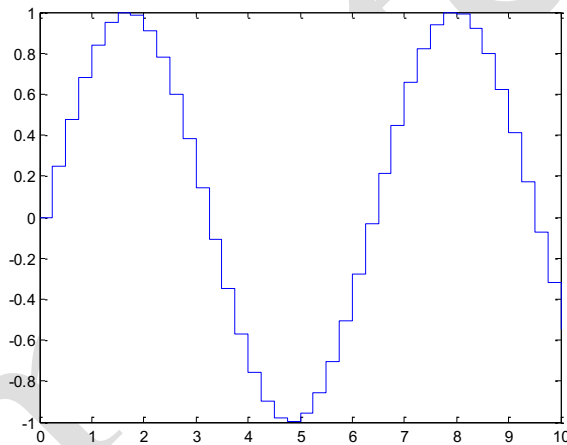

2D Graphics

Some of 2D functions in Matlab:

- plot
- area
- polar
- stairs
- pie
- bar

3D Graphics

Some of 3D functions in Matlab:

- plot3
- mesh
- pie3
- surf
- sphere

2D

Example 1

```
x = 0:0.2:20;  
y = sin(x)./sqrt(x+1);  
y(2,:) = sin(x/2)./sqrt(x+1);  
y(3,:) = sin(x/3)./sqrt(x+1);  
plot(x,y)
```

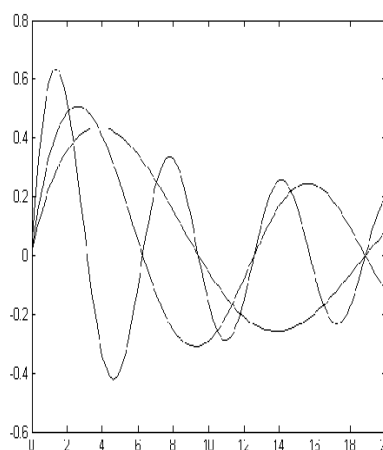

Example 2

```
clc  
clear  
close all  
x=0:0.1:10;  
y=sin(x);  
z=cos(x);  
subplot(1,2,1)  
plot(x,y,'r*');  
grid  
subplot(1,2,2)  
plot(x,z,'md');
```

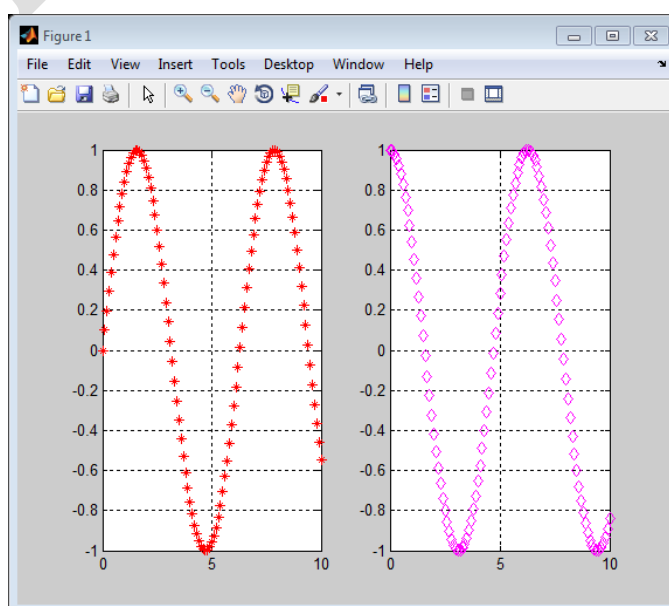

grid

Example 3

clc

clear

close all

x=0:0.1:10;

y=sin(x);

z=cos(x);

v=exp(x);

subplot(3,3,[1 2 3 4 5 6])

plot(x,y,'r*');

grid

subplot(3,3,7)

plot(x,z,'mo');

grid

subplot(3,3,9)

plot(x,v);

grid

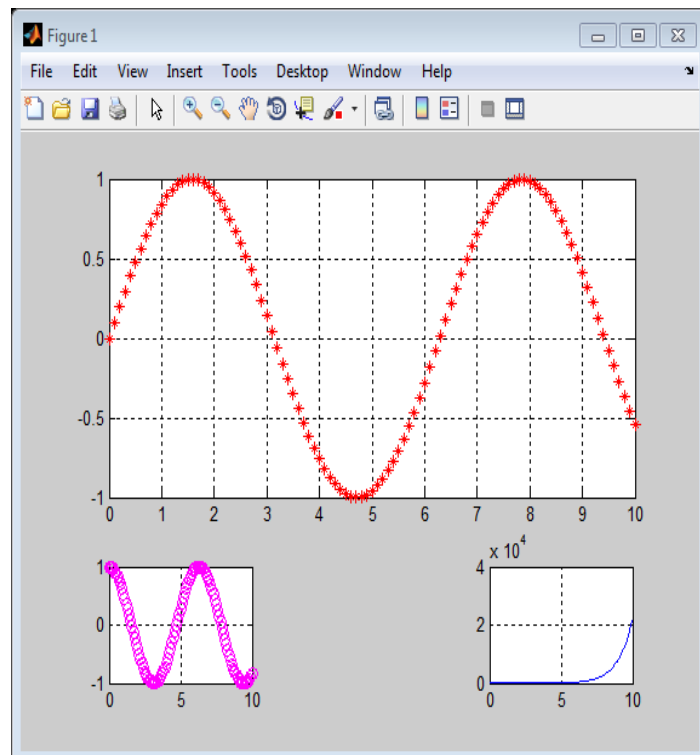

Example 4

x = 0 : 0.1 : 2*pi;

y1 = sin(x);

y2 = cos(x);

plot(x, y1, '-l', x, y2, '+')

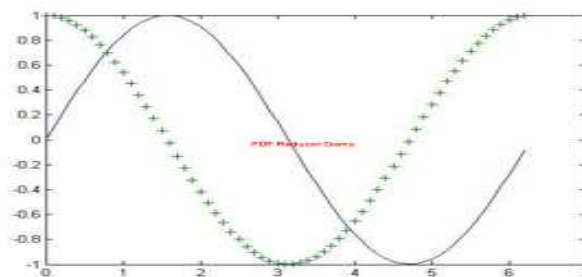

```
theta*5 :0.2 :0 = pi;
```

```
rho = theta.^2;
```

```
polar(theta, rho, '*')
```

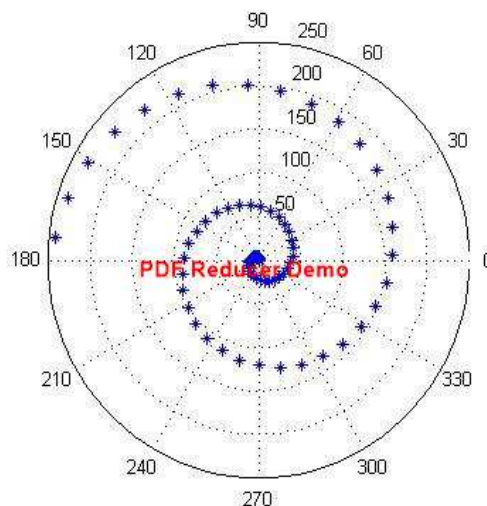

Example 5

```
x = [1 3 0.5 2.5 2];
explode = [0 1 0 0 0];
pie(x,explode);
colormap jet;
```

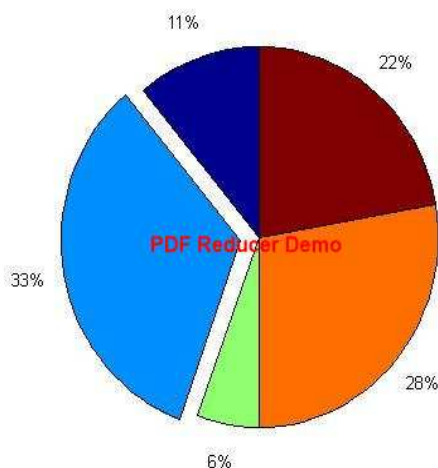

Example 6

```
Y = [1, 5, 3;
3, 2, 7;
1, 5, 3;
2, 6, 1];
area(Y);
title ('Area Plot');
```

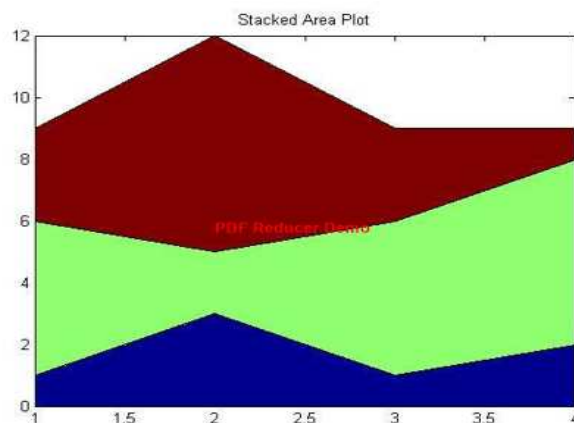

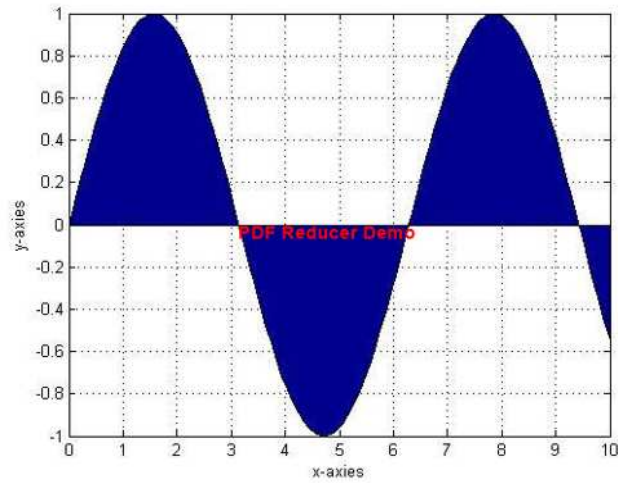

```
clc
clear
close all
x=linspace(0,10,100);
y=sin(x);
area(x,y);
grid
xlabel('x-axies');
ylabel('y-axies');
```



3D

Example 1

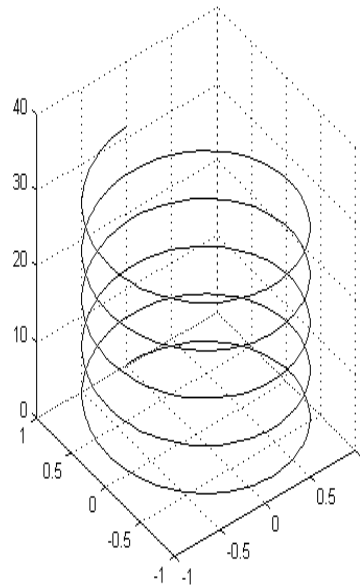
```
clc
clear
close all
t = 0:pi/50:10*pi;
plot3(sin(t),cos(t),t)
axis square;
grid
```



Example 2

```
x = [1 3 0.5 2.5 2];
explode = [0 1 0 0 0];
pie3(x,explode)
colormap hsv
```

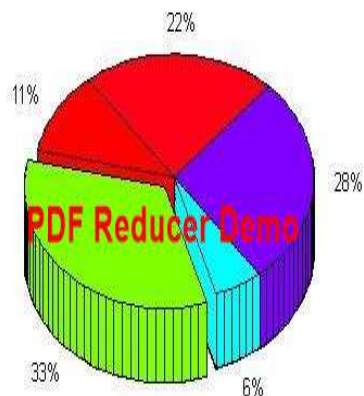

Example 3

figure
sphere
axis equal

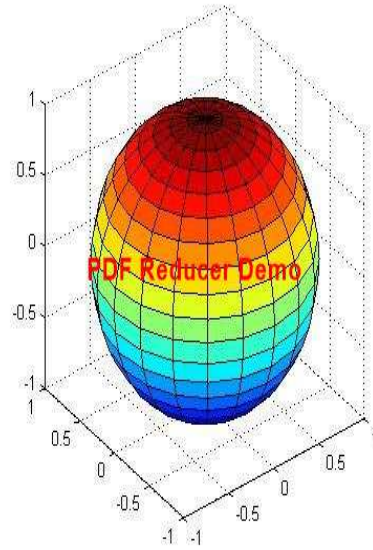

Example 4

Y = [5 2 1
8 7 3
9 8 6
5 5 5
4 3 2];
bar(Y)

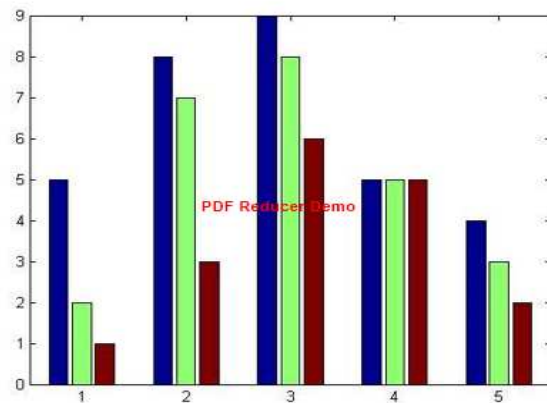

Y = [5 2 1
8 7 3
9 8 6
5 5 5
4 3 2];
bar3(Y)

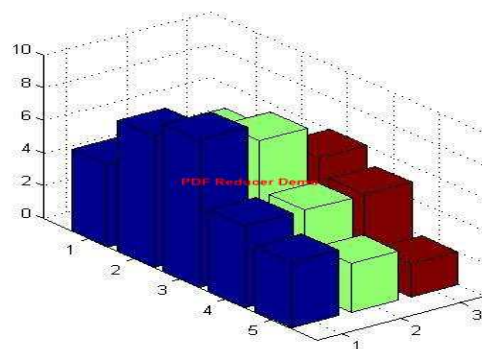

Subplot Example

```
t = 0:pi/20:2*pi;
```

```
[x,y] = meshgrid(t);
```

```
subplot(2,2,1)
```

```
plot(sin(t),cos(t))
```

```
axis equal
```

```
subplot(2,2,2)
```

```
z = sin(x)+cos(y);
```

```
plot(t,z)
```

```
axis([0 2*pi -2 2])
```

```
subplot(2,2,3)
```

```
z = sin(x).*cos(y);
```

```
plot(t,z)
```

```
axis([0 2*pi -1 1])
```

```
subplot(2,2,4)
```

```
z = (sin(x).^2)-(cos(y).^2);
```

```
plot(t,z)
```

```
axis([0 2*pi -1 1])
```

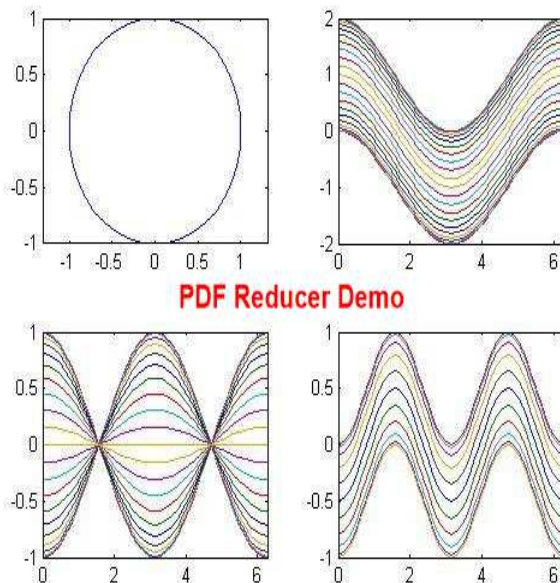

Exercise

Q1) Write Matlab script for draw the area of the following function: $f = \ln(x)$, $0 \leq x \leq 20$ then 40 point. And properties of first function is (red, plus, dashed), and Properties of second function (cay, star, dotted), Added three options in the graph.

Q2) Write Matlab script for draw two functions: $y = \sqrt{x} + 1, z = x^2 + 2$, $0 \leq x \leq 5\pi$. And properties of first function is (yellow, plus, dashed), and Properties of second function (cay, star, dotted), Added three options in the graph. Used the subplot command to display these functions on two windows on the same graph

Q3) Write Matlab script for draw two functions: $y = f = e^{-4t}, z = x^2$, $0 \leq x \leq 5\pi$. And properties of first function is (yellow, plus, dashed), and Properties of second function (cay, star, dotted), Added three options in the graph. Each graph must display on window.

Q4) calculate the percentage value the grade of student in mathematic department, then Write a script and draw a pie graph of the percentage, the graph should explode excellent sections at the following table.

A

pass	mid	good	Very good	excellent
56	30	20	12	5

a) Write Matlab script for draw the two following functions: $M = \sin(x), N = \cos^2(x)$, $0 \leq x \leq 2\pi$. Using 100 data point, each function must display on window. And properties of first function is (Black, diamond, dashed), and Properties of second function (blue, square, dotted), Added three options in the graph.

b) Evaluate with using the Matlab script, the solution of the following equations:

$$A+B-C+D=15$$

$$3A-6B+5C-D=6$$

$$-2A-5B+6C+D=8$$

$$A-9B-7C-5D=0$$

Q1) For the matrix $A = [1,2,3;4,5,6;7,8,9;10,11,12]$,using Matlab script

1- Draw the bar graph of the matrix A.

- 2- Find the matrix B which is a reshape of the matrix A, but with 6 rows and 2 columns.
- 3- Draw the stairs graph of the matrix B.
- 4- Two graph display on the same window.
- 5- **Q3) a)** Write Matlab script for draw the two following functions: $f = e^{-4t}$, $g = \cos(5t)$, $0 \leq x \leq 5$.
- 6- Used the subplot command to display these functions on two windows on the same
- 7- graph, and properties of first function is (red, plus, dashed), and Properties of second function (cay, star, dotted), Added three options in the graph.

Chapter five

Programming in

MATLAB

Chapter five

Programming in MATLAB

Input and fprintf

```
fx>> x=input('please enter a number :')
```

```
please enter a number : 100
```

```
x =
```

```
100
```

```
fx >> fprintf('%d',x)
```

```
100>>
```

```
fx >>
```

fprintf('format', x,...)

Format Code Description

- %d integer format
- %f Decimal format

Control code Description

- \n Start new line
- \t Tab

Text string,error message

- Text string are entered into matlab surrounded by single quotes

```
fx>> s='this is a text'
```

- Text string can be displayed with

```
fx>> disp('this is message')
```

- Error message are best display with

```
fx>> error('sorry, this is error')
```

Relational operators in MATLAB

Example	Operator	Relationship
$x == 5$	<code>==</code>	Equal to
$y \sim = 4$	<code>~=</code>	Not equal to
$b < 0$	<code><</code>	Less than
$u > v$	<code>></code>	Greater than
$5 \leq 7$	<code><=</code>	Less than or equal to
$4 \geq 3$	<code>>=</code>	Greater than or equal to

Control Structures

- If Statement Syntax

```

if (Condition_1)
    Matlab Commands
elseif (Condition_2)
    Matlab Commands
elseif (Condition_3)
    Matlab Commands
else
    Matlab Commands
end
    
```

Examples

```

if ((a>3) & (b==5))
    Some Matlab Commands;
end
    
```

```

if (a<3)
    Some Matlab Commands;
elseif (b~=5)
    Some Matlab Commands;
End
    
```

```

if (a<3)
    Some Matlab Commands;
else
    Some Matlab Commands;
end
    
```

Example 1

test.m script file

```
x=input('please enter a number :')
y=input('please enter a number :')
if x>y
fprintf('The number x is greater.\n' )
else
fprintf('The number y is greater.\n' )
end
```

Example 2

```
n = input('Enter an integer: ');
if (rem(n,2)==0)
fprintf('The integer %d is even.\n', n)
else
fprintf('The integer %d is odd.\n', n)
end
```

Example 3

```
a=input('Enter a number a: ');
b=input('Enter a number b: ');
fprintf('\n')
fprintf('1) Add a and b.\n')
fprintf('2) Subtract b from a.\n')
fprintf('3) Multiply a and b.\n')
fprintf('4) Divide a by b.\n')
fprintf('\n')
n=input('Enter your choice: ');
```

```

if n==1
fprintf('The sum of %0.2f and %0.2f is %0.2f.\n',a,b,a+b)
elseif n==2
fprintf('The difference of %0.2f and %0.2f is %0.2f.\n',a,b,a-b)
elseif n==3
fprintf('The product of %0.2f and %0.2f is %0.2f.\n',a,b,a*b)
elseif n==4
fprintf('The quotient of %0.2f and %0.2f is %0.2f.\n',a,b,a/b)
else
fprintf('Not a valid choice.\n')
end

```

Control Structures

- for loop syntax

```

for i=Index_Array
    Matlab Commands
end
%.....
for i=start:inc_value:stop
    Matlab Commands
End

```

Examples

<pre> for i=1:100 Some Matlab Commands; end </pre>
<pre> for j=1:3:200 Some Matlab Commands; end </pre>
<pre> for m=13:-0.2:-21 Some Matlab Commands; end </pre>
<pre> for k=[0.1 0.3 -13 12 7 -9.3] Some Matlab Commands; end </pre>

Example 4

```
>> for p=1:10
fprintf('%d\t',p)
end
1 2 3 4 5 6 7 8 9 10 >>
```

```
>> for p=1:2:10
fprintf('%d \t',p)
end
1 3 5 7 9 >>
```

Example 5

```
for k=5:2:13
fprintf('The square of %d is %d.\n', k, k^2)
end
```

```
The square of 5 is 25
The square of 7 is 49
The square of 9 is 81
The square of 11 is 121
The square of 13 is 169
```

Control Structures

- while Loop Syntax

```
while (condition)
    Matlab Commands
End
```

Example

```
while ((a>3) & (b==5))
    Some Matlab Commands;
end
```

Example 6

```
k=5;
while k<=13
fprintf('The square of %d is %d.\n', k, k^2)
k=k+2;
end
```

switch

- switch – Switch among several cases based on expression
- The general form of SWITCH statement is:

```
switch switch_expr
    case case_expr,
        statement, ..., statement
    case {case_expr1, case_expr2, case_expr3, ...}
        statement, ..., statement
    ...
    otherwise
        statement, ..., statement
end
```

Example 7

```
a=input('Enter a number a: ');
b=input('Enter a number b: ');
fprintf('\n')
fprintf('1) Add a and b.\n')
fprintf('2) Subtract b from a.\n')
fprintf('3) Multiply a and b.\n')
fprintf('4) Divide a by b.\n')
fprintf('\n')
n=input('Enter your choice: ');
fprintf('\n')
switch n
case 1
fprintf('The sum of %.2f and %.2f is %.2f.\n',a,b,a+b)
case 2
fprintf('The difference of %.2f and %.2f is %.2f.\n',a,b,a-b)
case 3
fprintf('The product of %.2f and %.2f is %.2f.\n',a,b,a*b)
case 4
fprintf('The quotient of %.2f and %.2f is %.2f.\n',a,b,a/b)
otherwise
fprintf('Not a valid choice.\n')
end
```

Programming in MATLAB

for Loop Example

Using the for loop to compute the Factorial

$$0! = 1$$

$$1! = 1$$

$$2! = 1 \times 2 = 2$$

$$3! = 1 \times 2 \times 3 = 6$$

$$4! = 1 \times 2 \times 3 \times 4 = 24$$

$$5! = 1 \times 2 \times 3 \times 4 \times 5 = 120$$

factorial.m script file

```
n =input('enter an integer number:')
```

```
x=1;
```

```
for i= 1:n;
```

```
    x =x*i;
```

```
end
```

```
fprintf('the factorial of % d is %d \n','n,x)
```

Assignment 1

Write the factorial program using while loop

if statement Example

The following example compute the grade of a student and print the result for each degree

grade.m script file

```
degree=input('Enter your degree: ');
fprintf('\n')
if ( degree <= 100 & degree >= 90)
fprintf('The grade of the student %0.2f is excellent.\n',degree)
elseif ( degree <= 90 & degree >= 80)
fprintf('The grade of the student %0.2f is very good.\n',degree)
elseif ( degree <= 80 & degree >= 70)
fprintf('The grade of the student %0.2f is good.\n',degree)
elseif ( degree <= 70 & degree >= 60)
fprintf('The grade of the student %0.2f is mid.\n',degree)
elseif ( degree <= 60 & degree >= 50)
fprintf('The grade of the student %0.2f is pass.\n',degree)
else
fprintf('Not pass .\n')
end
```

Assignment 2

Write the grade program using switch statement

Programming in MATLAB

Write a program to calculate the average value of a student degrees of five subjects, then print this average value , using

1- for loop

2- while loop

1) for loop

```
sum=0
for i = 1:5
degree=input('enter your degree=')
sum=sum+degree;
end
average = sum/5;
fprintf('The average of the student is: %0.2f \n',average)
```

2) while loop

```
sum=0;
i=1;
while i<=5;
degree=input('enter your degree=')
sum=sum+degree;
i=i+1;
end
average = sum/5;
fprintf('The average of the student is: %0.2f \n',average)
```

Write a program to test a number, when it is 1, print the number is positive, when the number is 0, print the number is zero, when the number is -1, print the number is negative. For all other numbers, print unknown using:

1- if statement

2- switch statement

1- if statement

```
number=input('enter a number:');  
if number==1  
fprintf( 'the number is positive \n');  
elseif number==0  
fprintf( 'the number is zero \n');  
elseif number==-1  
fprintf( 'the number is negative \n');  
else  
fprintf( 'unknown \n');  
end
```

2- switch statement

```
number=input('enter a number:');  
switch number  
case 1  
fprintf( 'the number is positive \n');  
case 0  
fprintf( 'the number is zero \n');  
case -1  
fprintf( 'the number is negative \n');  
otherwise
```

م.د. رنا بهجت اسماعيل، م. عادل عبد الكاظم و م.م. ايمان احمد قسم الرياضيات /المرحلة الثانية

```
fprintf( 'unknown \n');  
end
```

MATLAB allows to use one loop inside another loop.

the syntax for a nested for loop statement in MATLAB is as follows

```
for m = 1:j  
    for n = 1:k  
        <statements>;  
    end  
end
```

Write a program to calculate the production table using nested for loop

```
clc  
a=0;  
disp('-----')  
for i=1:10;  
    b=0;  
    for j=1:10;  
        c(j) =a*b;  
        b=b+1;  
    end  
    disp(c)  
    disp('-----')  
    a=a+1;  
end
```

String statements

s =input(statement' ,s') returns the entered text as a MATLAB string.

Example

```
day = input('enter a day: ', 's');  
switch day  
    case 'friday'  
        msgbox('the day is off')  
    case 'saturday'  
        msgbox(' the day is also off')  
    otherwise  
        msgbox(' you must go to college today')  
end
```

Loop Flow Diagram

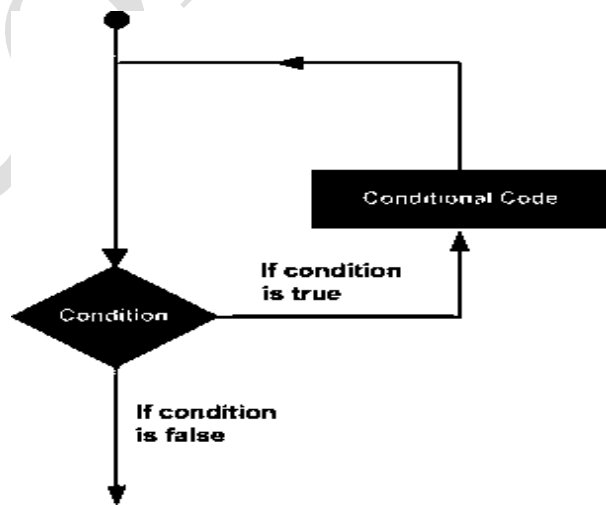

1) while loop example

```
a = 10;  
% while loop execution  
while( a <=20 )  
fprintf('value of a: %d \n', a);  
a = a + 1;  
end
```

1. output

```
value of a: 10  
value of a: 11  
value of a: 12  
value of a: 13  
value of a: 14  
value of a: 15  
value of a: 16  
value of a: 17  
value of a: 18  
value of a: 19  
value of a: 20
```

2) for loop

```
for a = 10:20  
fprintf('value of a: %d\n', a);  
end
```

2. output

```
value of a: 10  
value of a: 11  
value of a: 12  
value of a: 13  
value of a: 14
```

value of a: 15
value of a: 16
value of a: 17
value of a: 18
value of a: 19
value of a: 20

Break statement

The break statement terminates execution of **for** or **while** loop. Statements in the loop that appear after the break statement are not executed.

In nested loops, break exits only from the loop in which it occurs. Control passes to the statement following the end of that loop.

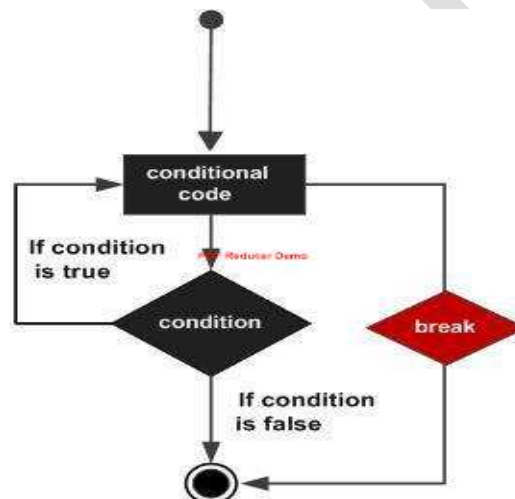

1) Break example

```
a = 10;  
% while loop execution  
while (a <=20 )  
fprintf('value of a: %d\n', a);  
a = a+1;  
if( a > 15)  
% terminate the loop using break statement  
break;  
end  
end
```

1. output

value of a: 10

value of a: 11

value of a: 12

value of a: 13

value of a: 14

value of a: 15

Continue statement

The continue statement is used for passing control to next iteration of for or while loop.

The continue statement in MATLAB works somewhat like the break statement. Instead of forcing termination, however, 'continue' forces the next iteration of the loop to take place, skipping any code in between

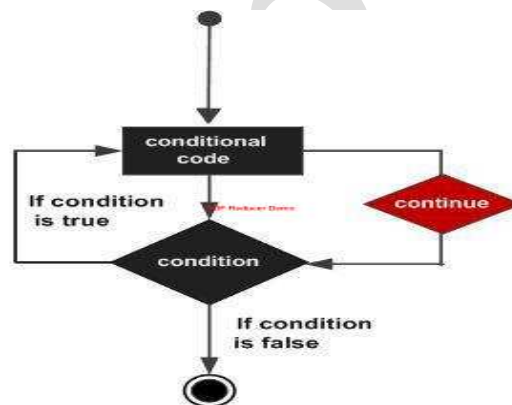

1) continue exam

```
a = 10;
%while loop execution
while a <= 20
if a == 15
% skip the iteration
a = a + 1;
continue;
end
fprintf('value of a: %d\n', a);
```

م.د. رنا بهجت اسماعيل، م. عادل عبد الكاظم و م.م. ايمان احمد قسم الرياضيات /المرحلة الثانية

```
a = a + 1;
```

```
end
```

1. output

value of a: 10

value of a: 11

value of a: 12

value of a: 13

value of a: 14

value of a: 16

value of a: 17

value of a: 18

value of a: 19

value of a: 20

Computer

Exercise

- Q/ Write m-file in Matlab program to print the square of even numbers for the interval (0-20) , and using one decimal format with while loop.
- Q/ Write a program .m script file to test a number, when the number is 1, print the number is positive when the number is 0, print the number is zero, when the number is -1, print the number is negative. For all other numbers, print unknown using if statement.
- Q/ Write m-file in Matlab program to print the square of odd numbers for the interval (1-20) and using one decimal format with for loop.
- Q/ Write a program .m script file to test a number, when the number is 1, print the number is positive when the number is 0, print the number is zero, when the number is -1, print the number is negative. For all other numbers, print unknown using switch statement.
- Q/ write m-file in matlab program to compute the factorial **W** using while loop.
- Q/ write m-file in matlab program to compute the factorial **W** using for loop.
- Q/Write a program to calculate the average value of a student degrees of seven subjects, then print this average value using for loop.
- Q/ Write a program to calculate the average value of student degrees of three subjects, then print this average value using while loop.

Q/ Write a program to calculate the production table using for loop.

Q/ Write m-file in Matlab program to print of even number using one decimal format with if statement.

Q/ Write m-file in Matlab program to print of even number using one decimal format with switch statement.

Q/ Write m-file in Matlab program to print of numbers from (1-20) using three decimal format with for loop.

Q/ Write m-file in Matlab program to print of numbers from (1-20) using three decimal format with while loop.

Q/ Write m-file in Matlab program to print the square numbers (5-15) by step two and using two decimal format with while loop.

Q/ Write m-file in Matlab program to print the square numbers (5-15) by step two and using two decimal formats with for loop.

Q/ Write a program .m script file to test a days, when the day is Friday, print ' the day is off ' when the day is Saturday, print 'the day is off', and otherwise days, print ' you must go to college today' using if statement.

Q/ Write a program .m script file to test a days, when the day is Friday, print ' the day is off ' when the day is Saturday, print 'the day is off', and otherwise days, print ' you must go to college today' using switch statement.